

PA 2046 High Performance Positioning System for Servotrack Writers



Resolution
4.68 nanoradians

Accuracy
35 nanoradians rms

Stroke
46 degrees

The PA 2046 positioning system will improve the performance of servotrack writers with its 46 degree stroke, rapid seek & settle time and ultra high resolution.

The PA2046 is an integrated positioner containing an asymmetrical rotary actuator and a shaft mounted MicroE Systems encoder. Designed for speed and stiffness, the actuator produces high torque through a stiff bearing/shaft assembly. The position encoder uses MicroE systems' patented diffractive technique to achieve 4.68 nanoradian resolution [when used with MC2000]. The actuator/encoder assembly delivers fast, solid motion with extremely fine resolution resulting in HDD track densities in excess of 100k tpi.

Specifications

Stroke	46 Degrees
Size	W: 82.6 mm 3.250" L: 93.7 mm 3.688" H: 73.0 mm 2.875"
Accuracy	35 nrad rms w/MicroE motion board
Resolution [14 bit interp.]	4.68 nanoradians 0.001 arc second
Inertia	4.74×10^{-3} oz-in-s ² 334.75 gram-cm ²
Inertially Balanced	No

Torque Specifications

Torque Constant	17.5 in-oz/amp $\pm 15\%$ @ 70°F
Maximum Continuous Operating Torque	8.75 in-oz $\pm 10\%$ continuous operation @ 0.5 amps

Motor Properties

Coil Inductance	1.7 mH ± 0.2 mH
Coil Impedance	$8.0\Omega \pm 0.2\Omega$
Power Input	1.0 amp maximum for 1 minute 0.5 amp continuous input

Environmental Conditions

Humidity	10% to 90% (non-condensing)
Operating Temp.	5 °C to 35 °C (41 °F to 95 °F)
Storage Temp.	-20 °C to 50 °C (-4 °F to 122 °F)
Cleanroom Specifications	Class 100K or better

System Specifications

Mechanical Information

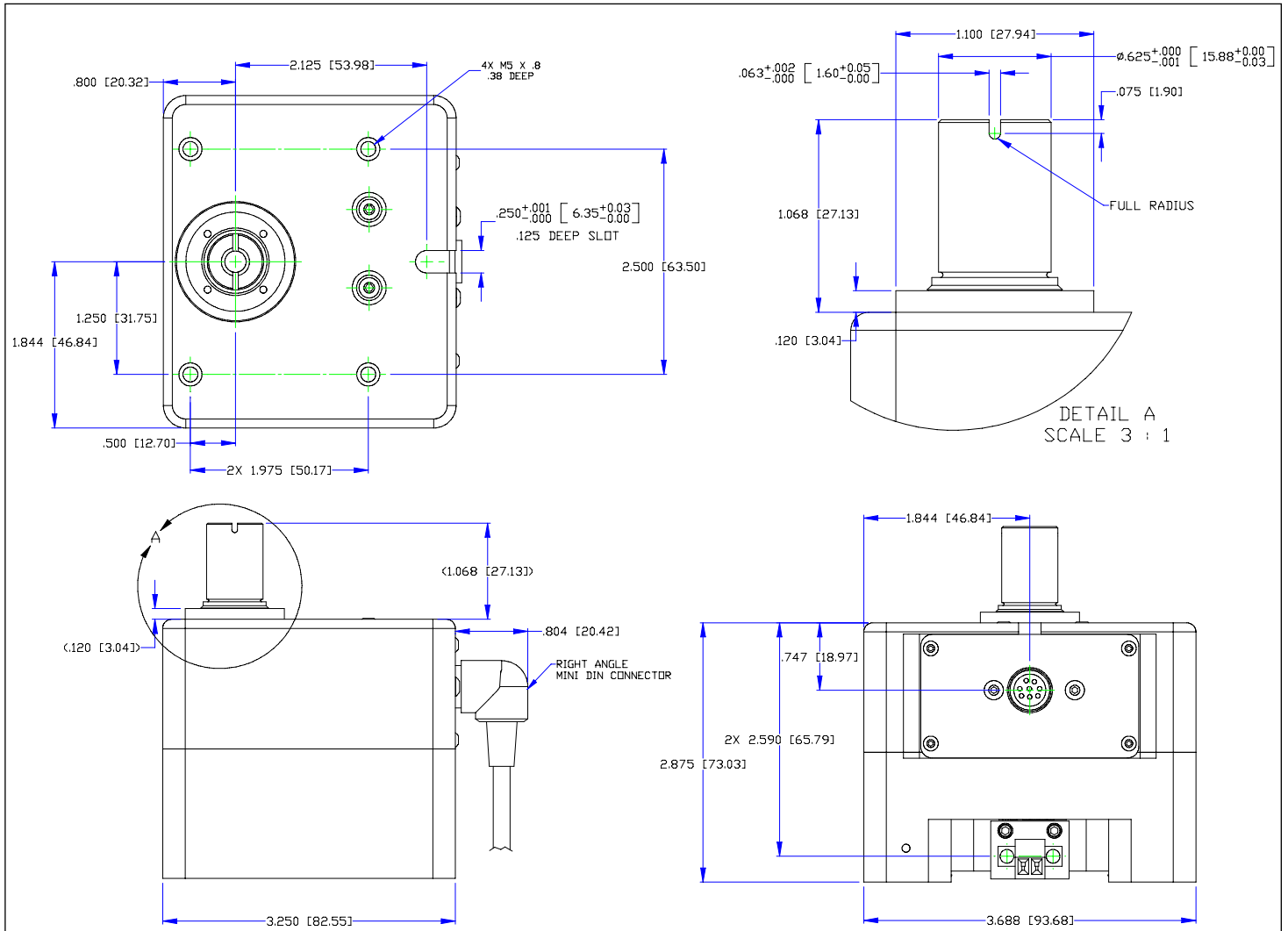

BODE PERFORMANCE

Primary Torsional Mode above 6 kHz x 6.6391 kHz y: -13.2141dB

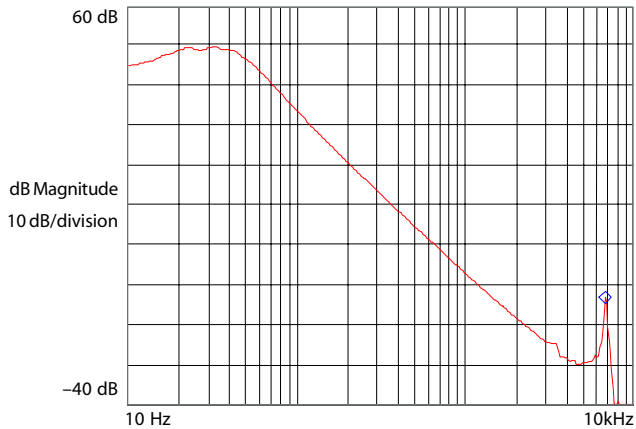

Typical Mechanical Bode for a PA 2046 (no load)

All Specifications are subject to change. All data is accurate to the best of our knowledge. MicroE Systems is not responsible for errors.