

MCB2 Motion Control Board

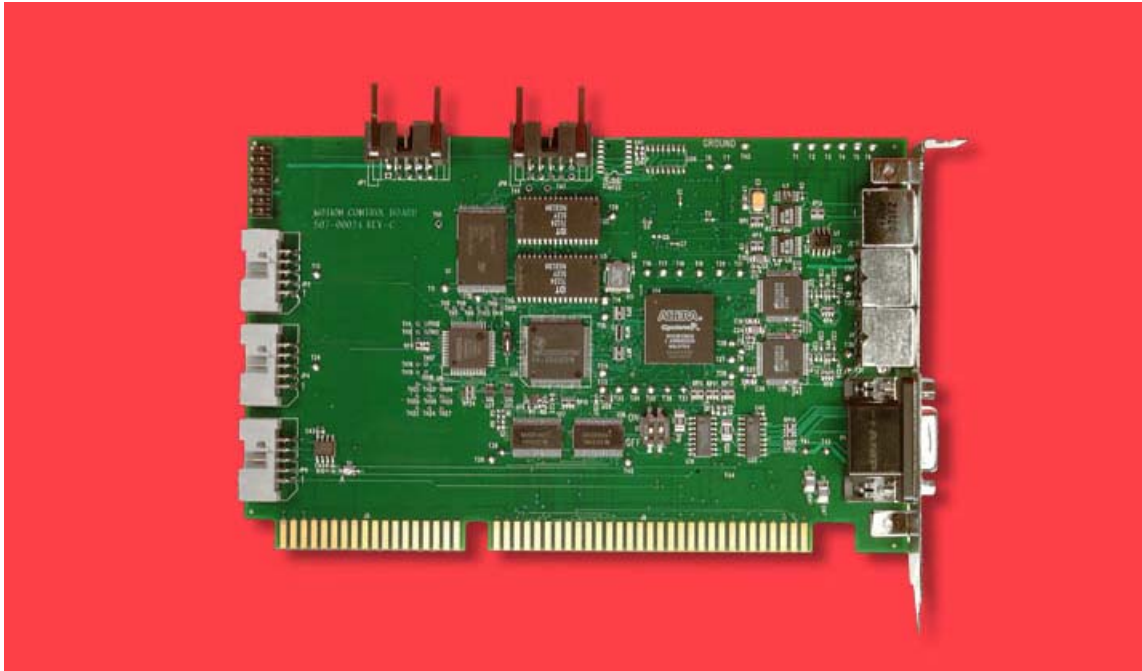

The MCB2 motion control board can control multiple loops as well as providing position resolutions down to 4.68 nanoradians with 1 LSB repeatability.

The MCB2 can control up to two closed loops in a motion system. Each axis supports single or dual sensor inputs [digitally averaged] with sample rates up to 40KHz. Using standard PID position compensation and proprietary gain & offset interpolation algorithms, the MCB2 provides position control resolutions down to 4.68 nanoradians with 1 LSB repeatability.

Offered in a variety of configurations, the MCB2 has the performance and versatility to handle the most demanding motion control applications. The board is supplied with C source code to ease implementation into OEM systems, or the optional Windows based SPSII software is available for stand alone applications.

SPECIFICATIONS

Size	Half size ISA Bus
Axes	Two
Sample Rate	20 kHz [40 kHz single axis]
Sample Buffers	Two
Points/Buffer	4,096
Processor	16-Bit Fixed Point
Oper. Voltage	+5 Volts @ 2 Amps [maximum]

MOTION SPECIFICATIONS

Compensation	PID [Proportional, Integral, Derivative]
Filter Modes	User programmable b-quad [2/channel]
Profile Modes	Trapezoidal, S-Curve, Electronic Gear, and User-Defined Feed Forward
Interpolation	x16,384 [14 bits]
Position Range	$\pm 1,073,741,824$
Velocity Range	$\pm 32,768$ counts/sample

USER CONNECTIONS

Encoder Input	8-pin MiniDIN [sin/cos, differential 4 volts pp]
DAC Output	7-pin MiniDIN [16-bit DAC, +/- 10 Volts]
Other I/O	One analog input per axis 2 semiarbitrary analog outputs

ENVIRONMENTAL CONDITIONS

Humidity	10 to 90% RH non-condensing
Operating Temp.	0° to 55° C [32° to 131° F]
Storage Temp.	-20° to 70° C [-4° to 158° F]

Internal Block Diagram

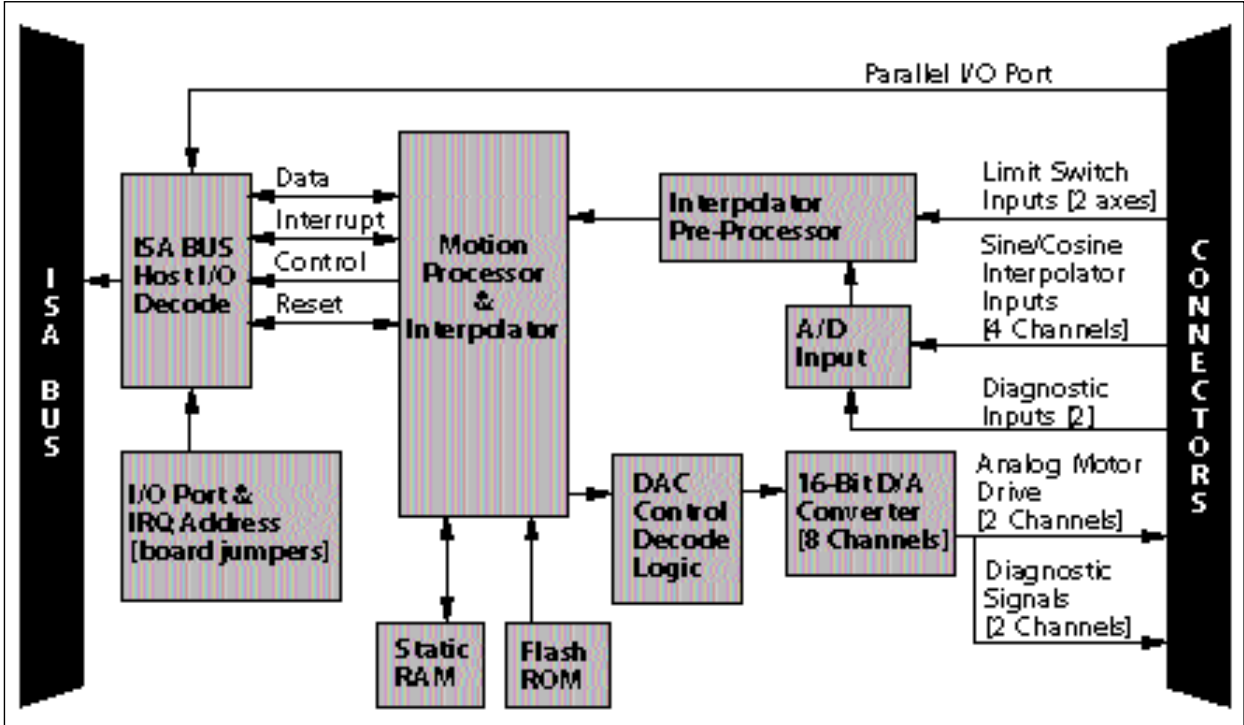

All Specifications are subject to change. All data is accurate to the best of our knowledge. MicroE Systems is not responsible for errors.

Ordering Information: MCB2