

Mercury™ 1500 Digital Output Encoder Systems

Factory Set Resolution to 0.50µm

Reflective Linear and Rotary Encoders

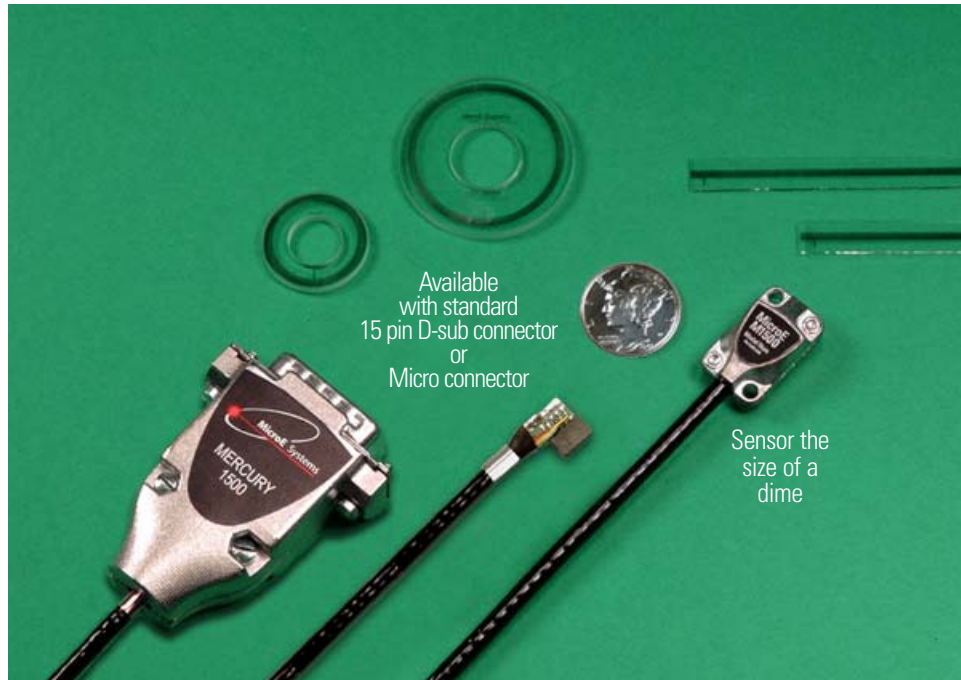

Resolution

Factory Set:

x4, x8, x20, or x40

Linear: 5µm, 2.5µm, 1.0µm, or 0.50µm

Rotary: 6,600 to 655,000 CPR

Accuracy

Linear: ± 1µm available
± 3µm to ± 5µm standard

Rotary: Up to ± 2.1 arc-sec

Output

A-quadr-B and Digital Index Window

The Mercury 1500 encoder system includes the sensor, double shielded cable, your choice of connector, and either a linear or rotary glass scale. Mercury's space-saving, integrated configuration gives OEM system designers a breakthrough in performance.

Imagine what you can do with this!

Reduce the cost and size of your system, and increase its performance all at once. MicroE Systems' Mercury 1500 kit encoders are available in two styles. The M1500S, an RS-422 compliant 15 pin standard D-sub connector and the M1500H, an RS-422 compatible 5x2 micro-connector for tight spaces. Simply stated, the M1500 is smaller, higher performance, faster to install, and easier to use than any other encoder. The tiny sensor fits into very tight spaces, has broad alignment tolerances for fast and easy setup and works in both linear and rotary applications. The entire Mercury 1500S encoder is EMI shielded for use in the toughest environments. With standard digital A-quadr-B output, select the Mercury 1500 encoder with the resolution required by your application.

Standard features

- Small sensor with ultra-low Z height; flush screw mounting
- Sensor is 8.4mm (H) x 12.7mm (W) x 20.6mm (L) and weighs 1.6g
- Available with 15 pin standard D connector or micro-connector
- A-quadr-B output and Index window
- Factory set interpolation x4, x8, x20, x40 for resolutions of 5µm to 0.50µm (linear); 6,600 CPR to 655,000 CPR (rotary)
- Entire system is EMI shielded
- Bi-directional index signal
- Index mark at the center or end of the glass scale (linear)
- Alignment Tool enables fast set up (see pg 2)

Table of Contents

System & Sensor pg. 2-6

Scales pg. 7-8

Ordering Information pg. 9

Optional Features & Accessories

- SmartPrecision Alignment Tool



- Glass scale length or diameter:
Linear lengths from 5mm to 2m
Rotary diameters from 12mm to 108mm



- Cable length of 0.5m, 1m, 2m or custom
- SmartPrecision Software for set up

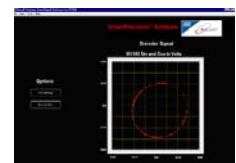

System Configurations

Standard and Optional Equipment

M1500S Encoder System Standard Equipment



Encoder Sensor
Same for linear and rotary scales.

Controller
Interface Cable

M1500S
RS-422 compliant
15 pin standard
D-sub connector

M1500H
RS-422 compatible
5 x 2 header
Micro-connector

SmartPrecision™ Alignment Tool - SSAT 1500

Provides fast set up; the built-in LED indicators make alignment fast and easy, eliminating the need for an oscilloscope.

The RS232 Interface Adapter provides power to the encoder and connections to a PC. This is included with the Alignment Tool.

M1500H Encoder System Standard Equipment



Optional Software

SmartPrecision™ Software

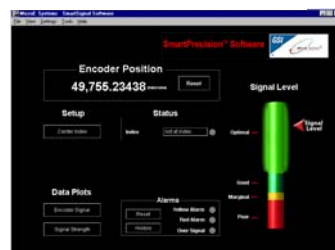

Optional software lets you view signal strength, Lissajous plots, position data and diagnostics.

Broader Alignment Tolerances, Increased Standoff Clearance, Smallest Sensor and More

Why Mercury Encoders Make It Easier To Design High Performance Into Your Equipment

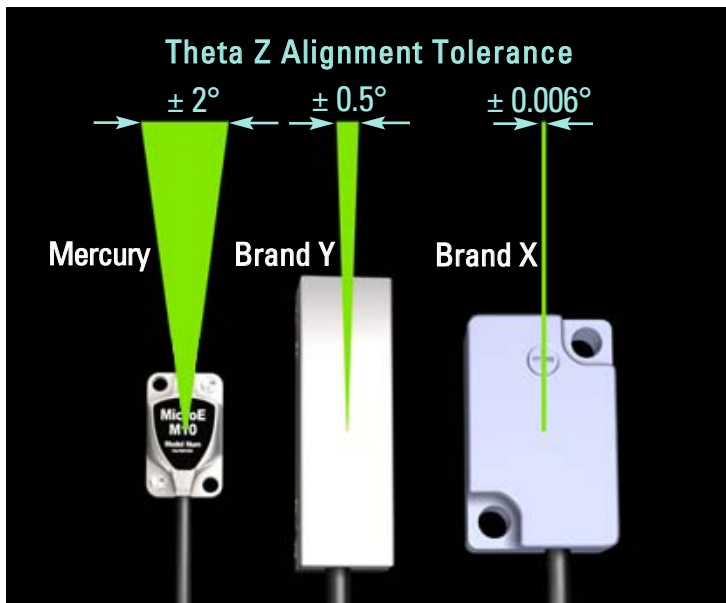

Eliminate the Frustration of Touchy Encoder Alignment

Mercury Solves this Problem for Good

Fussy alignment is no longer a concern. With Mercury's patented PurePrecision™ optics, advanced SmartPrecision™ electronics and LED alignment indicators, you can push the sensor against your reference surface, tighten the screws and you're finished. Try that with brand X or Y.

This performance is possible thanks to relaxed alignment tolerances, particularly in the theta Z axis. Mercury offers a ± 2° sweet spot— that's a 300% improvement over the best competitive encoder. And that will result in dramatic savings in manufacturing costs.

No other commercially available encoder is easier to align, easier to use, or easier to integrate into your designs.

Alignment Tolerance Comparison**

	Mercury*	Brand X	Brand Y	Mercury vs. Best Competitor
Z Standoff	± 0.15mm	± 0.1mm	± 0.1mm	Mercury is 50% better
Y	± 0.20mm for linear ± 0.10mm for rotary ≥19mm dia.	± 0.1mm	unspecified	Mercury is 100% better
theta X	± 1.0°	unspecified	± 1.0°	
theta Y	± 2.0°	± 0.1°	± 1.0°	Mercury is 100% better
theta Z	± 2.0°	± 0.006°	± 0.5°	Mercury is 300% better

*Measured at a constant temperature for one axis at a time with all other axes at their ideal positions.

**Based on published specifications

Mercury Can Reduce System Size and Cost

Mercury's sensor height is 44% shorter than competitive encoders, making it easy to fit into your design. This reduction can also cut total system weight and cost by allowing the use of smaller motors and stages. Safe system operation is also enhanced thanks to Mercury's generous standoff clearance— 200% greater than other encoders. And its standoff tolerance is 50% greater than the best alternative.

This significantly relaxes mechanical system tolerances, while reducing system costs.

Mechanical Dimension Comparison**

	Mercury	Brand X	Brand Y	Mercury vs. Best Competitor
Sensor Z height	8.4mm	23mm	15mm	44% better
Standoff clearance	2.4mm	0.5mm	0.8mm	200% better
Standoff tolerance	± 0.15mm	± 0.1mm	± 0.1mm	50% better
System height	11.7mm	28.5mm	15.8mm	26% better

**Based on published specifications

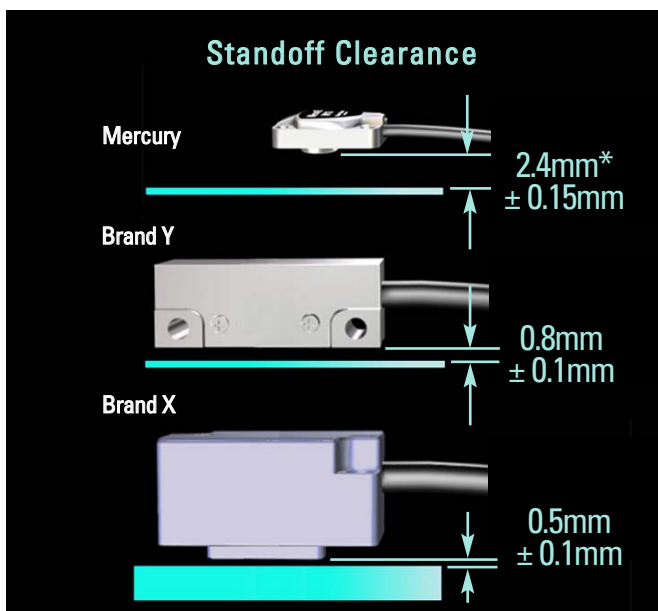

* Dimensions shown illustrate encoder system standoff clearance; see Mercury Encoder Interface Drawings for correct design reference surfaces.

System Specifications

Resolution and Maximum Speed

Mercury 1500 systems have factory set interpolation: x4, x8, x20, x40. Below is the table of available resolutions.

Linear - 20µm grating pitch

Interpolation	Resolution	Maximum Speed
x4	5.000µm/count	7200mm/s
x8	2.500µm/count	7200mm/s
x20	1.000µm/count	7200mm/s
x40	0.500µm/count	7200mm/s

Rotary - 20µm grating pitch

Rotary Glass Scale Diameter Fundamental Resolution Interpolation
Below is a table of the available resolutions.

0.472" [12.00mm]	1650 CPR		x4	x8	x20	x40
		interpolated resolution (CPR)	6,600	13,200	33,000	66,000
		interpolated resolution (arc-sec/count)*	196.4	98.2	39.2	19.64
		interpolated resolution (µrad/count)*	952	476	190.3	95.2
		maximum speed (RPM)	13090	13090	13090	13090
0.750" [19.05mm]	2500 CPR		x4	x8	x20	x40
		interpolated resolution (CPR)	10,000	20,000	50,000	100,000
		interpolated resolution (arc-sec/count)*	129.6	64.8	25.9	12.96
		interpolated resolution (µrad/count)*	628	314	125.6	62.8
		maximum speed (RPM)	8640	8640	8640	8640
1.250" [31.75mm]	4096 CPR		x4	x8	x20	x40
		interpolated resolution (CPR)	16,384	32,768	81,920	163,840
		interpolated resolution (arc-sec/count)*	79.1	39.6	15.82	7.91
		interpolated resolution (µrad/count)*	383	191.7	76.6	38.3
		maximum speed (RPM)	5273	5273	5273	5273
2.250" [57.15mm]	8192 CPR		x4	x8	x20	x40
		interpolated resolution (CPR)	32,768	65,536	163,840	327,680
		interpolated resolution (arc-sec/count)*	39.6	19.78	7.92	3.96
		interpolated resolution (µrad/count)*	191.7	95.8	38.3	19.17
		maximum speed (RPM)	2637	2637	2637	2637
4.250" [107.95mm]	16384 CPR		x4	x8	x20	x40
		interpolated resolution (CPR)	65,536	131,072	327,680	655,360
		interpolated resolution (arc-sec/count)*	19.78	9.89	3.96	1.978
		interpolated resolution (µrad/count)*	95.8	47.9	19.16	9.58
		maximum speed (RPM)	1318	1318	1318	1318

* Resolution values shown are approximate. To calculate exact resolution values, convert from CPR (Counts Per Revolution) to the desired units.

Note: Specifications assume XOR function which is available in all standard controllers.

All Specifications are subject to change. All data is accurate to the best of our knowledge. MicroE Systems is not responsible for errors.

System Specifications

System

Grating Period	20 μ m
System Resolution	5 μ m, 2.5 μ m, 1.00 μ m, or 0.50 μ m (linear)
Linear Accuracy*	Better than $\pm 1\mu$ m** available; contact MicroE Better than $\pm 3\mu$ m** up to 130mm, $\pm 5\mu$ m from 155mm to 1m, $\pm 5\mu$ m per meter from 1m to 2m

*Maximum peak to peak error over the specified movement when compared to a NIST-traceable laser interferometer standard, used at room temperature and with MicroE interpolation electronics.

**Or +/- one quadrature count, whichever error value is greater.

Rotary Accuracy*	Scale O.D.	Microradians**	Arc-Seconds**
	12.00mm	± 100	± 21
	19.05mm	± 63	± 13
	31.75mm	± 38	± 7.8
	57.15mm	± 19	± 3.9
	107.95mm	± 10	± 2.1

*Based on ideal scale mounting concentricity

**Or +/- one quadrature count, whichever error value is greater.

Sensor Size

W:	12.70mm	0.500"
L:	20.57mm	0.810"
H:	8.38mm	0.330"

Operating and Electrical Specifications

Power Supply	5VDC $\pm 5\%$ @ 60mA
Temperature	
Operating:	0 to 70°C
Storage:	-20 to 70°C
Humidity:	10 - 90% RH non-condensing
EMI:	M1500S: Entire system is EMI/RFI protected M1500H: Customer provides shielding at cable termination
Shock:	1500G 0.5 ms half sine (Sensor)
Sensor Weight:	5.0g (Sensor without cable)
Cable:	Double Shield. Diameter: 3.6mm (0.142") Flex Life: 20 x 10 ⁶ cycles @ 20mm bending radius

Mechanical Information - Sensor with Standard D-sub Connector

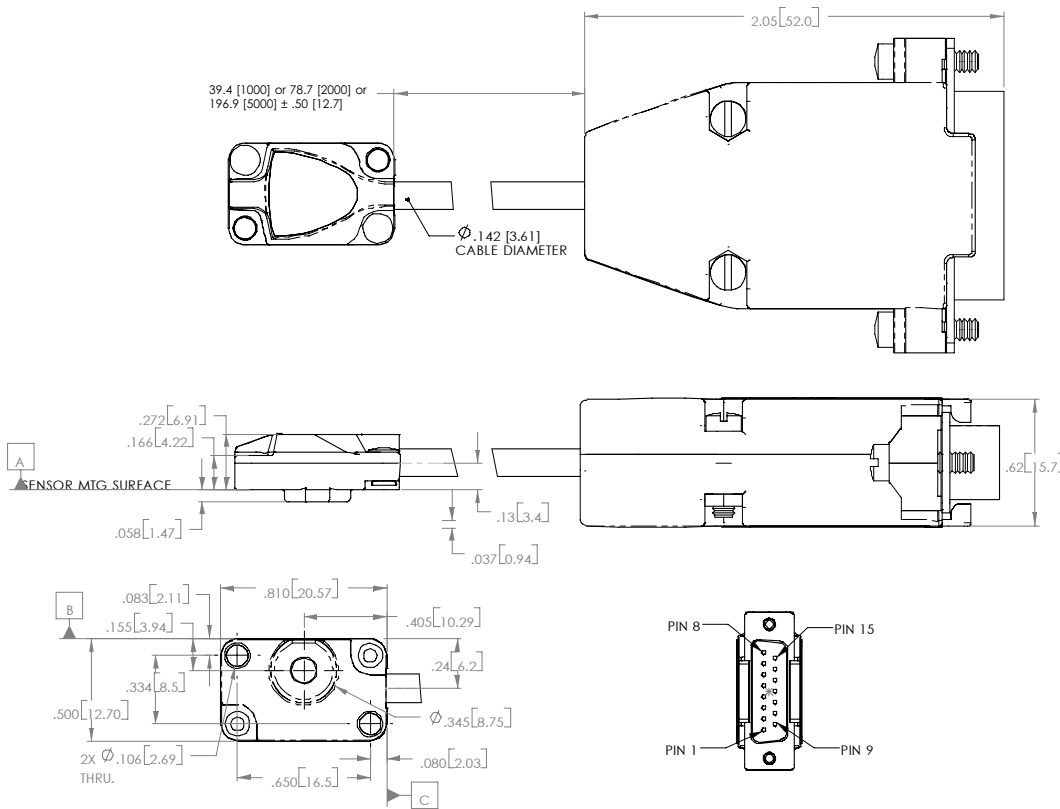

Mercury 1500S Outputs

15-pin Standard Male D-sub connector

PIN	FUNCTION
1	Reserved - do not connect
2	Reserved - do not connect
3	Reserved - do not connect
4	A - quadrature
5	A + quadrature
6	Reserved - do not connect
7	Sine+***
8	Cosine+***
9	B- quadrature
10	B+ quadrature
11	Reserved - do not connect
12	+5VDC
13	Ground
14	Index Window+
15	Index Window-

*** Analog outputs are for sensor alignment only and are nominally 0.85Vpp with 1.7V offset.

Index Window
Pin 14 on M1500S and
pin 6 on M1500H

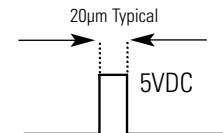

Mechanical Information - Sensor with Micro-connector

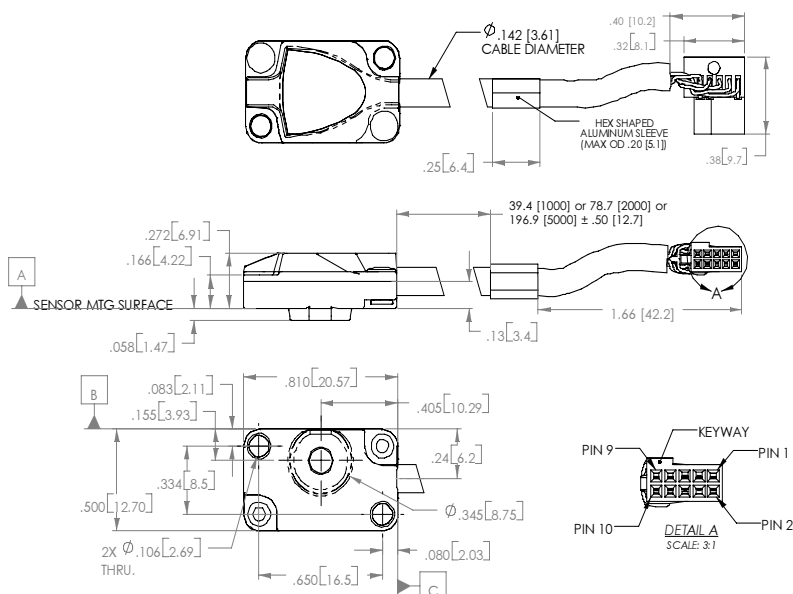

Mercury 1500H Outputs

Micro-connector (Female 5 x 2 Header)

PIN	FUNCTION
1	Sine+***
2	Index Window -
3	Cosine+***
4	Ground
5	A + quadrature**
6	Index Window +
7	A - quadrature**
8	+5VDC
9	B+ quadrature**
10	B- quadrature**

**Compatible with RS-422 receiver

*** Analog outputs are for sensor alignment only and are nominally 0.85Vpp with 1.7V offset.

Note: See user manual for guidelines on cable strain relief and grounding.

Scale Specifications

Standard and Customized Scales

MicroE Systems offers a wide array of chrome on glass scales for the highest accuracy and best thermal stability. Easy to install, standard linear and rotary scales meet most application requirements. Customized linear, rotary, and rotary segment scales are available where needed. All scales include an optical index. Mercury's glass scales save time by eliminating motion system calibrations or linearity corrections required by other encoders, and provide better thermal stability than metal tape scales.

Options include:

- *Standard linear*: 18mm - 2m
- *Standard rotary*: 12mm - 107.95mm diameter, with or without hubs
- *Custom linear**: special lengths, widths, thickness, index mark locations and special low CTE materials
- *Custom rotary**: special ID's, OD's (up to 304.8mm), index mark outside the main track and special low CTE materials
- *Mounting of hubs for rotary scales*: MicroE Systems can mount and align standard, custom, or customer-supplied hubs
- *Rotary segments**: any angle range; wide range of radius values

*Custom scales or rotary segments are available in OEM quantities. Contact your local MicroE Systems sales office.

Standard Short Linear Scales

130mm and Shorter

Key: inches[mm]

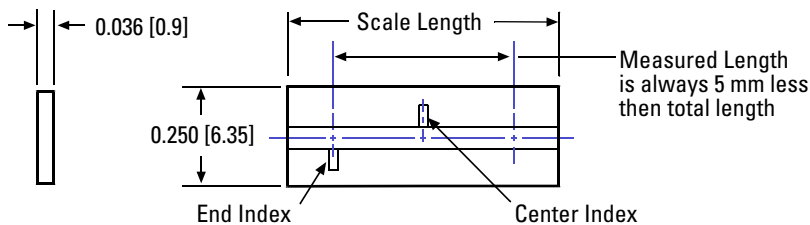

Specifications

Accuracy	±3µm standard ±1µm available
Material	Soda lime glass
Typical CTE	8ppm/°C
Index	Center or End

Model	L18	L30	L55	L80	L105	L130
Scale Length	0.709 [18]	1.181 [30]	2.165 [55]	3.150 [80]	4.134 [105]	5.118 [130]
Measured Length	0.512 [13]	0.984 [25]	1.969 [50]	2.953 [75]	3.937 [100]	4.921 [125]

Custom scales available

Standard Long Linear Scales

155mm and Longer

Key: inches[mm]

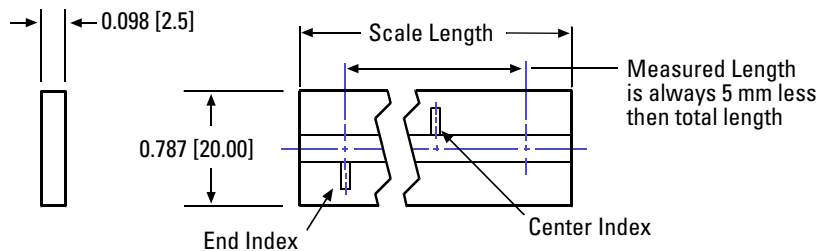

Specifications

Accuracy	±5 µm <1m ±5 µm/m >1m
Material	Soda lime glass
Typical CTE	8ppm/°C
Index	Center or End

Model	L155	L225	L325	L425	L525	L1025	L2025
Scale length	6.102 [155]	8.858 [225]	12.795 [325]	16.732 [425]	20.669 [525]	40.354 [1025]	79.724 [2025]
Measured length	5.906 [150]	8.661 [220]	12.598 [320]	16.535 [420]	20.472 [520]	40.157 [1020]	79.528 [2020]

Custom scales available

Standard Rotary Scales

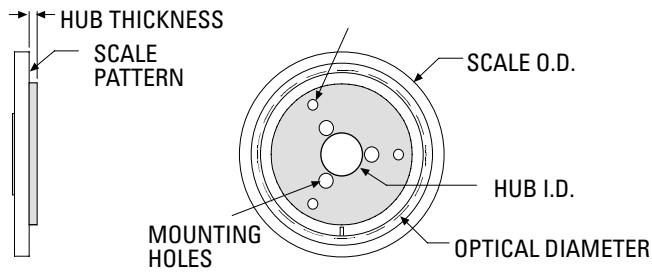

Specifications

Material	Soda lime glass
Typical CTE	8ppm/°C

Key: inches[mm]

Model No.	Scale Outer Diameter	Scale Inner Diameter	Optical Diameter	Hub Inner Diameter +0.0005/-0.0000	Hub Thickness	Fundamental CPR
R1206	0.472 [12.00]	0.250 [6.35]	0.413 [10.50]	0.1253 [3.18]	0.040 [1.02]	1650
R1910	0.750 [19.05]	0.375 [9.52]	0.627 [15.92]	0.1253 [3.183]	0.040 [1.02]	2500
R3213	1.250 [31.75]	0.500 [12.70]	1.027 [26.08]	0.2503 [6.358]	0.050 [1.27]	4096
R5725	2.250 [57.15]	1.000 [25.40]	2.053 [52.15]	0.5003 [12.708]	0.060 [1.52]	8192
R10851	4.250 [107.95]	2.000 [50.80]	4.106 [104.30]	1.0003 [25.408]	0.080 [2.03]	16384

Custom scales available

How to Order Mercury 1500 Encoder Systems

To specify your Mercury encoder with the desired scale, level of interpolation, maximum output frequency, cable length and software, consult the chart below to create the correct part number for your order. Call MicroE Systems' Rapid Customer Response team for more information [508] 903-5000.

Example (Linear Encoder): M1510-S-8-L55-C1 Example (Rotary Encoder): M1510-S-40-R1910-HA

<u>M15XX</u>	–	<u>Connector Type</u>	–	<u>Interpolation</u>	–	<u>Scale Model</u>	–	<u>Scale Mounting</u>
M1510 = 1m cable M1520 = 2m cable M1550 = 5m cable		S = Standard 15 pin D-sub H = Micro- connector		4 = 4x 8 = 8x 20 = 20x 40 = 40x		Lxxx or Rxxxx		For linear scales: T = Tape mounting C1 = 3 scale clamps* C2 = 10 scale clamps**

* 3 clamps for linear scales up to 130mm
** 10 clamps for linear scales 155mm or longer

All Specifications are subject to change. All data is accurate to the best of our knowledge.
MicroE Systems is not responsible for errors.

Hubs for Rotary Scales:
NH = Without Hub
HE = for R1206
HA = for R1910
HB = for R3213
HC = for R5725
HD = for R10851

How to Order SmartPrecision Alignment Tool

Example: Alignment Tool for Mercury 1500 encoder, 120 VAC = SSAT1500-H-120

<u>SSAT1500</u>	–	<u>Connector</u>	–	<u>Voltage</u>
		H = micro connector for M1500H S = 15-pin Std. D-sub connector for M1500S		120 = 120 VAC, 60Hz US Std. 2-prong plug 220 = 220 VAC, 50Hz European Std. 2-prong plug

How to Order SmartPrecision Software

Optional for SSAT1500 Alignment Tool

SmartPrecision Software

SSWA-AT = SmartPrecision software on CD

All Specifications are subject to change. All data is accurate to the best of our knowledge.
MicroE Systems is not responsible for errors.

