

THESE DRAWINGS AND SPECIFICATIONS ARE THE PROPERTY OF MicroE Systems Corp. AND SHALL NOT BE REPRODUCED OR COPIED OR USED AS THE BASIS FOR MANUFACTURE OR SALE OF APPARATUS WITHOUT EXPRESS WRITTEN AUTHORIZATION FROM MicroE Systems Corp.

REVISIONS				
LTR	ECO	DESCRIPTION	DATE	APPROVED
S3	---	INITIAL	10/18/06	MF
4	1969	INDEX LIMIT LENGTH WAS 20mm. CHANGED TO 16mm. SEE ECO	2/11/08	MF
5	1985	SENSOR HEIGHT 6.6 WAS 6.63, CABLE LENGTH 37.1 WAS 26.0	3/14/08	VB

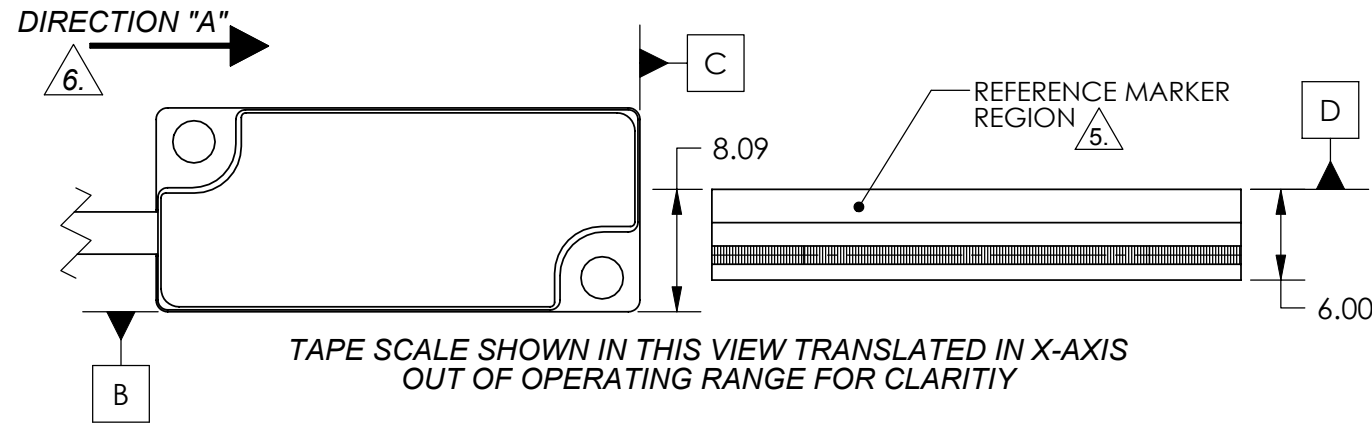

TAPE SCALE SHOWN IN THIS VIEW TRANSLATED IN X-AXIS OUT OF OPERATING RANGE FOR CLARITY

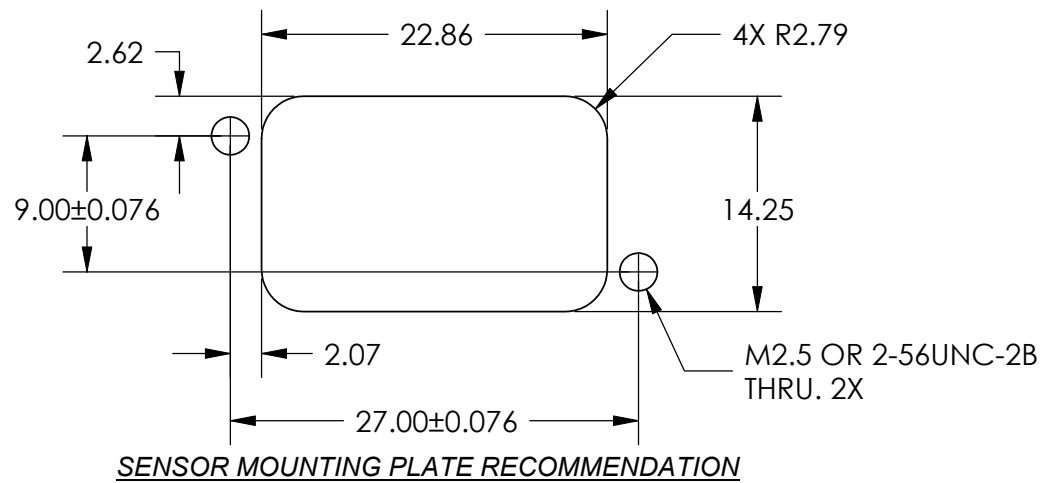

SENSOR MOUNTING PLATE RECOMMENDATION

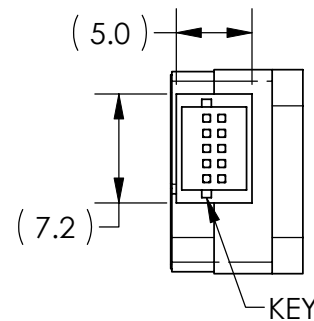

- NOTES:
- RECOMMENDED MOUNTING HARDWARE: 2-56 or M2.5 SCREWS
 - IF BENCHING PINS ARE TO BE USED, PINS MUST BE PLACED ALONG DATUM EDGES OF SENSOR FOR PROPER ALIGNMENT. (REFERENCE DATUMS B1, B2, AND C1).
 - HEIGHT OF SENSOR BENCHING PINS MUST BE A MINIMUM OF 4.06mm IN HEIGHT FROM DATUM A.
 - RECOMMENDED SENSOR MOUNTING PLATE THICKNESS: MINIMUM: 4 SCREW THREADS MAXIMUM: ALLOW CLEARANCE TO SCALE AND SCALE MOUNTING HARDWARE (BENCHING SURFACES, TRENCHES, ETC.)

5. SEE PAGE 2 FOR DIMENSIONS FOR LOCATIONS OF REFERENCE MARKERS.
 6. SEE INTERFACE DRAWING ID-00340 (INTERPOLATOR ELECTRONICS) FOR DIRECTIONALITY.

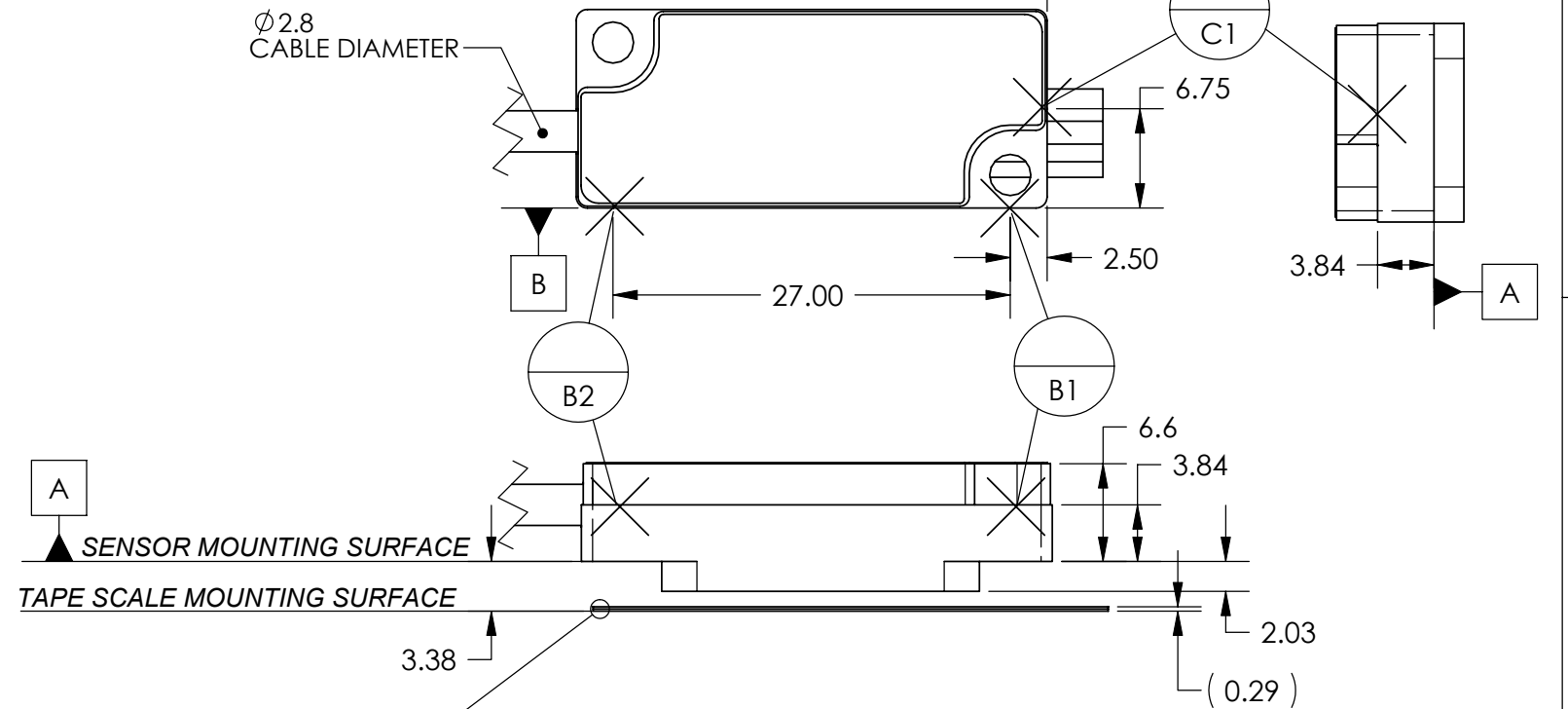

METAL TAPE SCALE
 ADHESIVE BACKING (TAPE SCALE MOUNTING SURFACE)

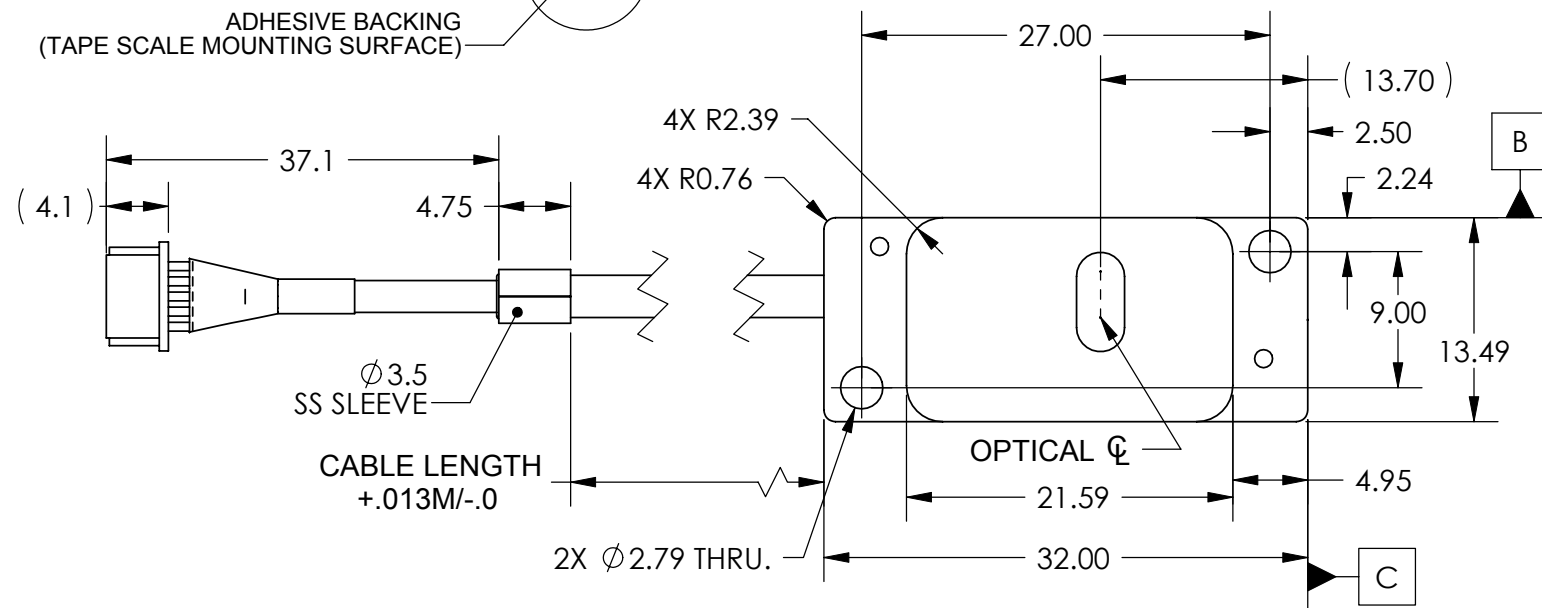

Cable Lengths
.5M
1M
3M
5M

UNLESS OTHERWISE SPECIFIED
 ALL DIMENSIONS ARE IN MILLIMETERS
 DIM. APPLY AFTER PROCESSING
 INTERPRET ALL GEOMETRIC TOLS.
 PER ANSI Y14.5M-1994

TOLERANCES ARE:
 DECIMALS: .X ± .25 ANGULAR: ±30 MIN.
 .XX ± .13

APPROVALS	DATE
DRAWN: S.BUTURLIA	9/20/06
CHECKED:	
ENGRG: A.GOLDMAN	10/18/06
MFG ENG: T.GARCIA	10/18/06
QA: A.VILLARROEL	10/18/06

UNITS: mm

GSI MicroE Systems
 Division of GSI

8 Erie Drive
 Natick, MA 01760

DESCRIPTION: INTERFACE, ENCODER, 20um, TAPE SCALE w/INDEX AND REFERENCE MARKERS, MERCURY II SENSOR

SIZE: B	DWG. NO.: ID-00336	REV.: 5
---------	--------------------	---------

SCALE: CAD FILE: 3RD ANGLE PROJECTION SHEET 1 OF 3

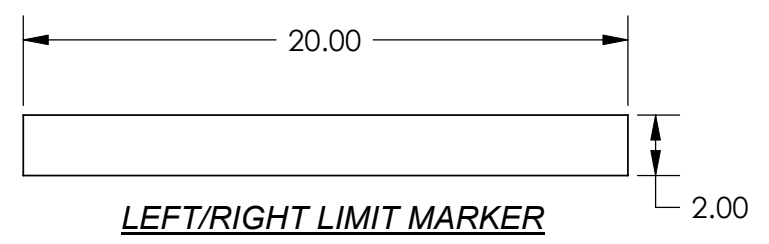
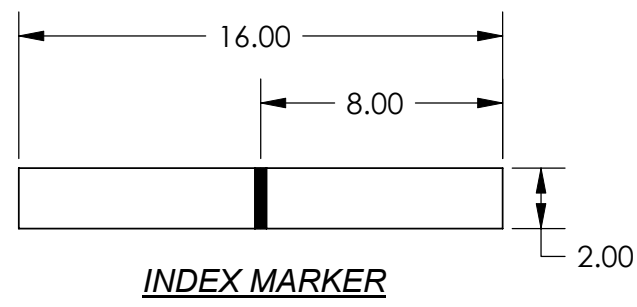
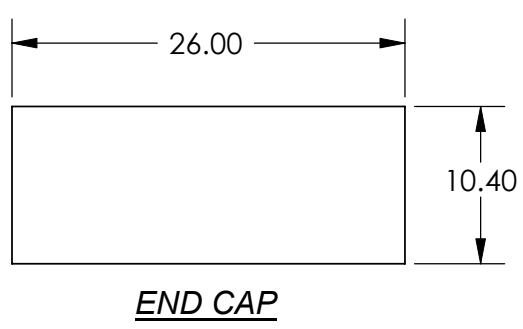
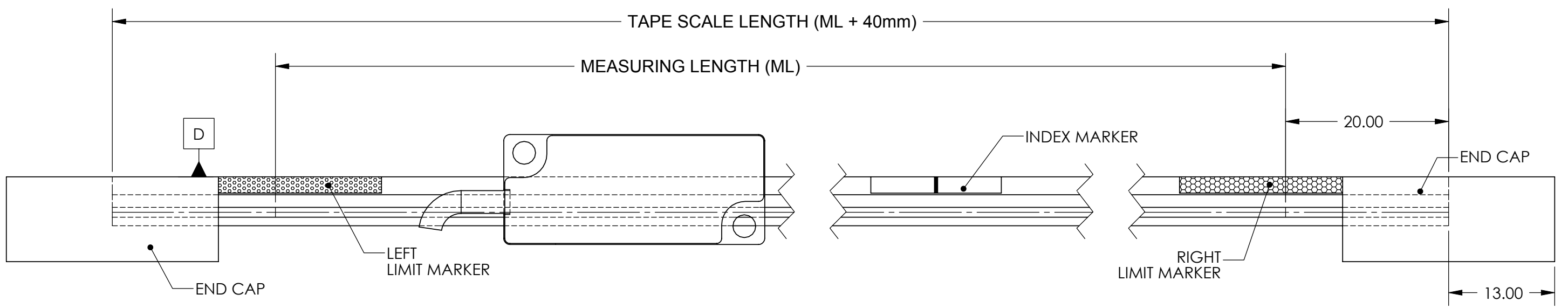

- NOTES:**
1. BEFORE PLACING INDEX MARKERS, LIMIT MARKERS, AND END CAPS, REMOVE BLUE PROTECTIVE FILM FROM TAPE SCALE.
 2. NOTE DATUM EDGE OF TAPE SCALE AND REFERENCE MARKER REGION BEFORE APPLYING MARKERS.
 3. END CAPS, LIMITS AND INDEX MARKERS ARE OPTIONAL (SEE INSTALLATION MANUAL).
 4. LIMIT MARKERS CAN BE PLACED AT ENDS OF TAPE SCALE WHEN END CAPS ARE NOT USED.
 5. END CAPS, LIMITS AND INDEX MARKERS SHALL NOT OVERLAP (MAY CAUSE INTERFERENCE WITH SENSOR).
 6. FOR LONGER OR SHORTER LENGTHS OF MARKERS CALL MICROE SYSTEMS FOR DETAILS.

UNITS: mm

GSI		MicroE Systems Division of GSI	
		8 Erie Drive Natick, MA 01760	
DESCRIPTION: INTERFACE, ENCODER, 20um, TAPE SCALE w/INDEX AND REFERENCE MARKERS, MERCURY II SENSOR			
SIZE B	DWG. NO. ID-00336	REV. 5	
SCALE:	CAD FILE:	3RD ANGLE PROJECTION SHEET 2 OF 3	

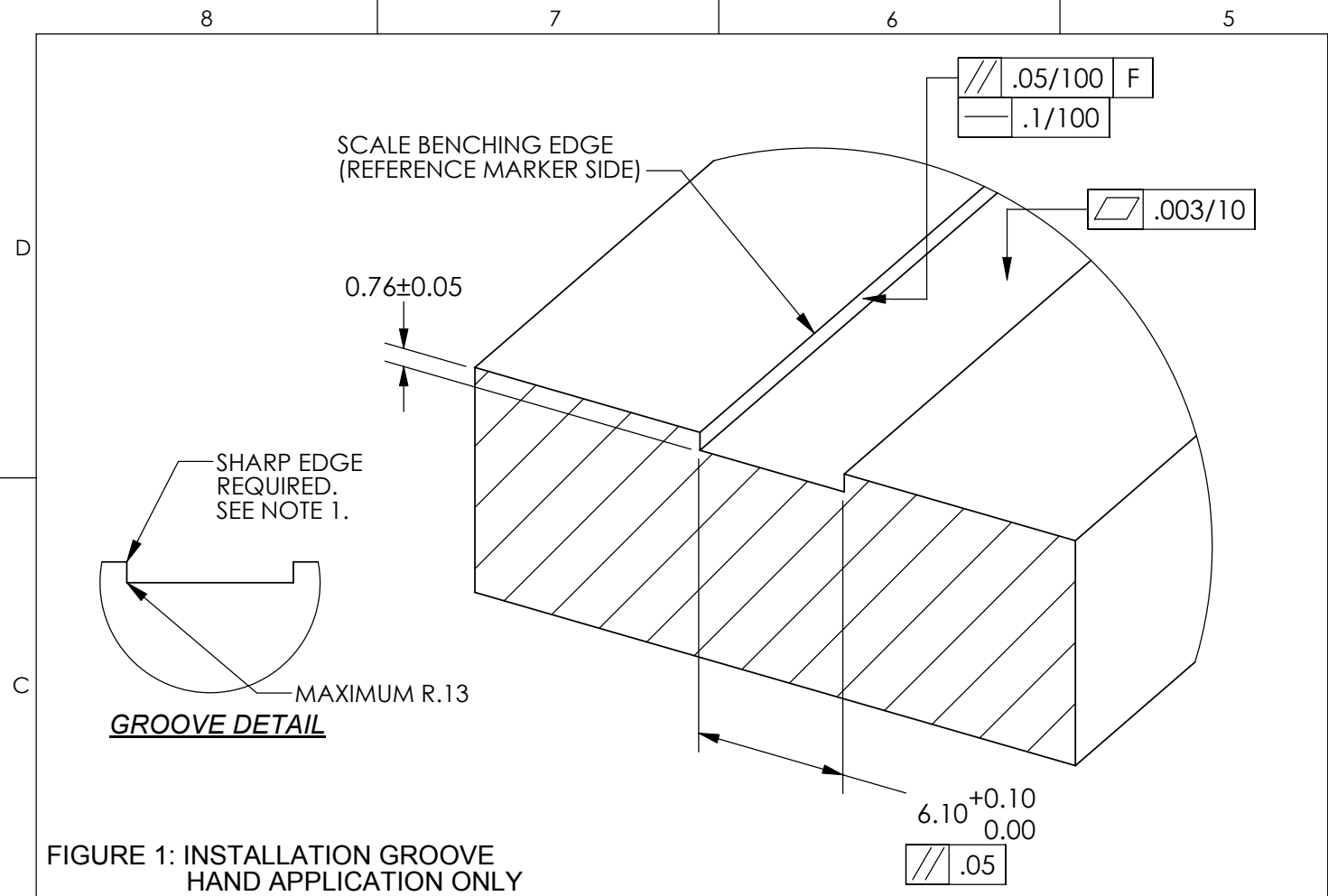

FIGURE 1: INSTALLATION GROOVE
HAND APPLICATION ONLY
F = MACHINE GUIDEWAY

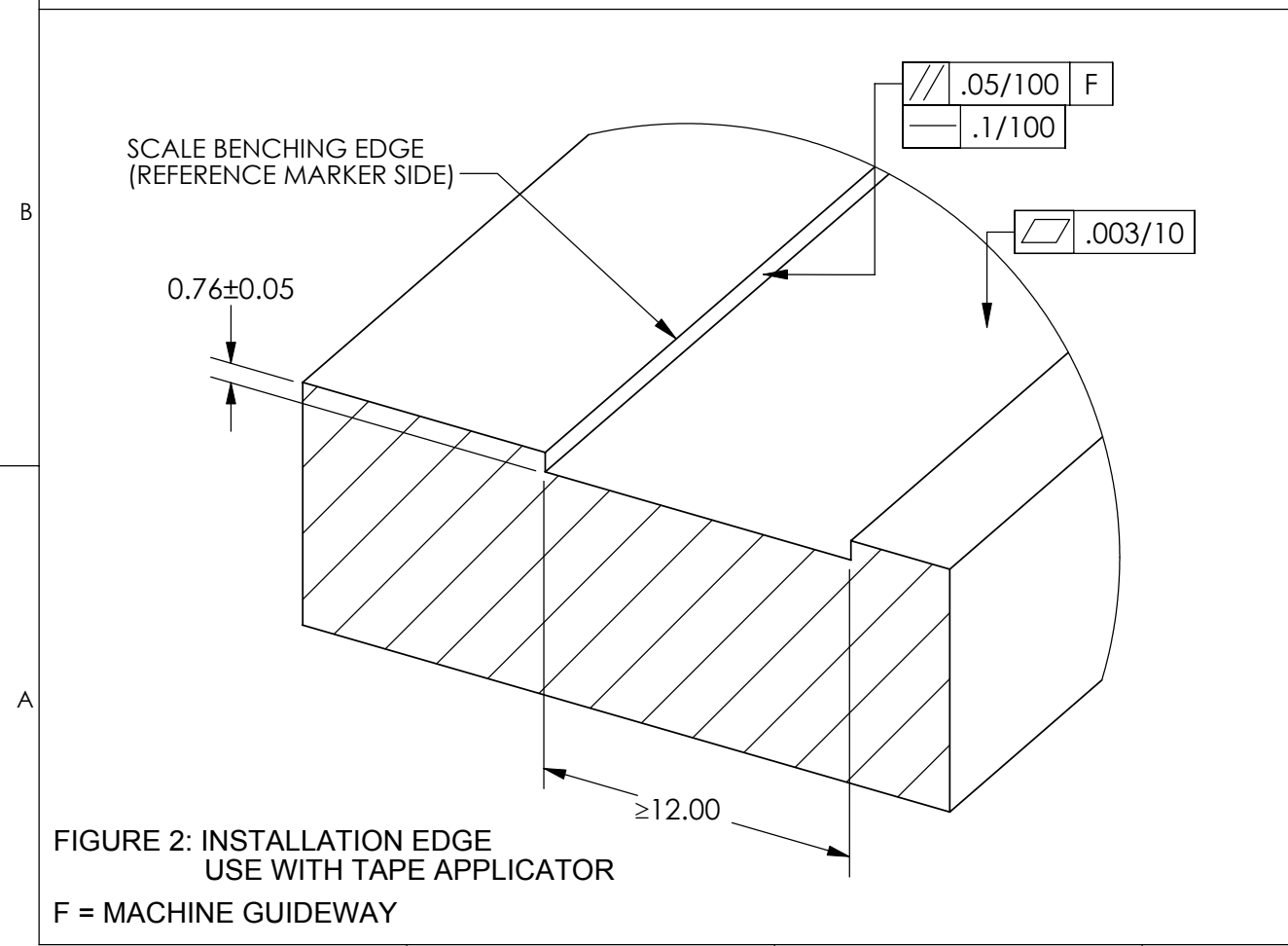

FIGURE 2: INSTALLATION EDGE
USE WITH TAPE APPLICATOR
F = MACHINE GUIDEWAY

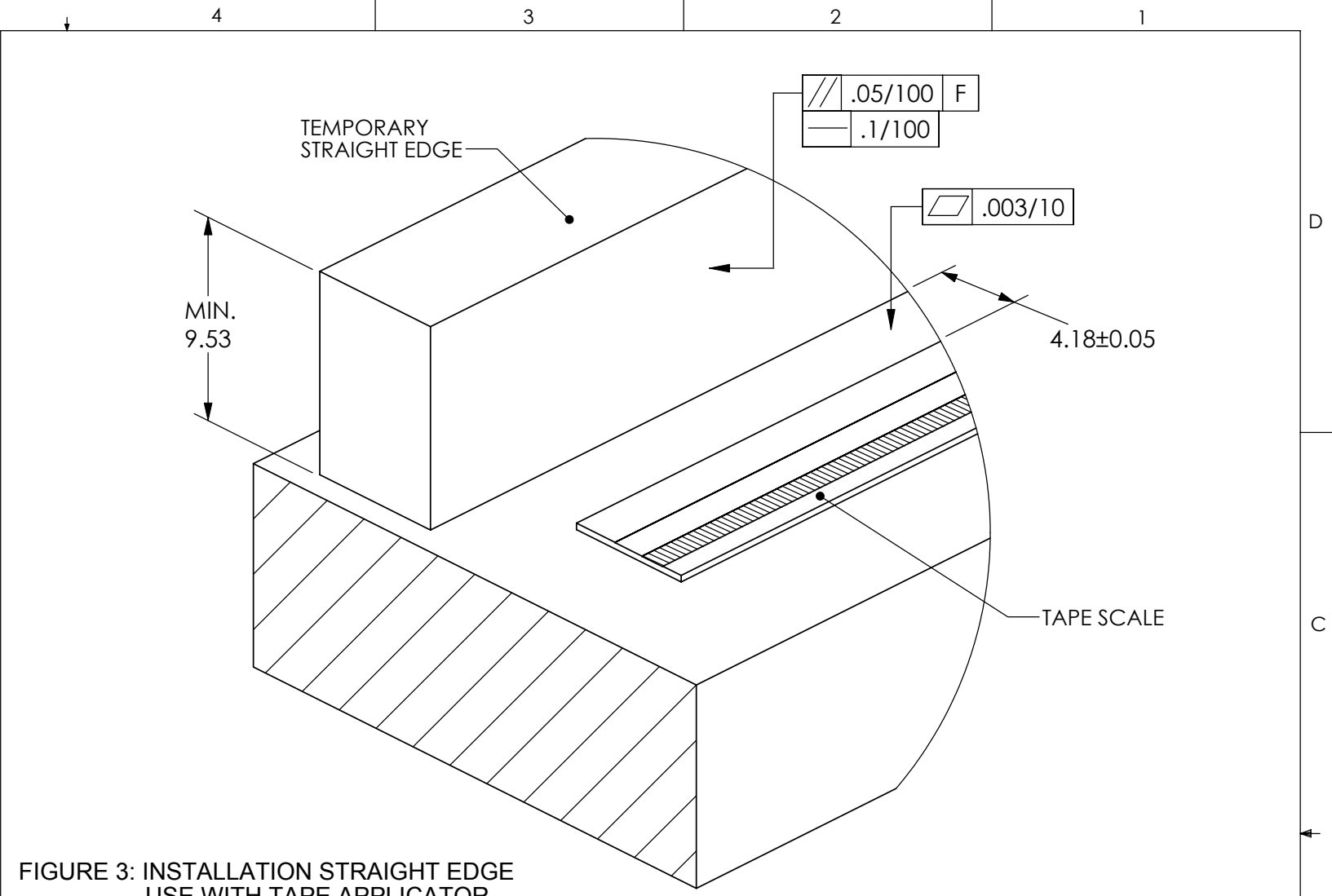

FIGURE 3: INSTALLATION STRAIGHT EDGE
USE WITH TAPE APPLICATOR
F = MACHINE GUIDEWAY

NOTES:

1. MICROE SYSTEMS RECOMMENDS UTILIZING AN EDGE AS A GUIDE IN ORDER TO MAINTAIN STRAIGHTNESS OF THE SCALE DURING MOUNTING. THIS EDGE MAY BE TEMPORARY OR PERMANENT AND SHOULD FOLLOW THE APPLICATION GUIDELINES IN FIGURES 1-3.
2. THE TAPE SCALE APPLICATOR TOOL IS RECOMMENDED FOR INSTALLATION OF SCALES AND, IN PARTICULAR, THOSE LONGER THAN 250 MILLIMETERS. SHORTER SCALES MAY BE APPLIED EITHER BY HAND OR WITH APPLICATOR TOOL. PLEASE SEE INSTRUCTION MANUAL FOR DETAILS.
3. THE INSTALLATION METHOD SHOWN IN FIGURE 1 SHOULD INVOLVE HAND INSTALLATIONS ONLY. THE APPLICATOR TOOL IS NOT COMPATIBLE WITH THIS METHOD. IN ADDITION END CAPS CANNOT BE USED WITH THIS METHOD.
4. FOR APPLICATIONS WHERE MACHINING THE MOUNTING SURFACE IS NOT DESIRED, A TEMPORARY STRAIGHTEDGE CAN BE USED. A STAINLESS STEEL RULE MAY BE USED AS IN FIGURE 2 IF THE RULE MEETS THE THICKNESS REQUIREMENT. OTHERWISE, THE TEMPORARY STRAIGHTEDGE MAY BE USED AS SHOWN IN FIGURE 3.
5. IN FIGURE 3, THE OUTSIDE REFERENCE SURFACE OF THE TOOL SLIDES AGAINST THE TEMPORARY EDGE, AND THE TAPE SCALE IS THEREFORE OFFSET FROM THE EDGE AS SHOWN. IF THIS OFFSET IS TOO SMALL FOR THE APPLICATION, THE CUSTOMER MAY DESIRE TO CREATE A SPACER THAT CAN ATTACH TO THE OUTSIDE SURFACE OF THE TOOL. PLEASE SEE INSTRUCTION MANUAL FOR DETAILS.
6. IN FIGURES 1 AND 2, THE SCALE BENCHING EDGE IS INTENDED TO AID THE INSTALLATION OF REFERENCE MARKERS. FOR APPLICATIONS SUCH AS IN FIGURE 3, THE CUSTOMER MAY USE A TEMPORARY BENCHING SURFACE TO INSURE THE PROPER INSTALLATION OF THE REFERENCE MARKERS. PLEASE SEE INSTRUCTION MANUAL FOR DETAILS. THE EDGE OF THE GROOVE OR STRAIGHTEDGE MUST BE SHARP ON BENCHING SIDE IN ORDER FOR APPLICATOR TO USE AS A GUIDE. IN ORDER FOR THE TAPE SCALE TO MOUNT CLOSE TO THIS EDGE, A MAXIMUM RADIUS OF .13 SHOULD BE USED WHERE THE EDGE MEETS THE BOTTOM OF THE MOUNTING SURFACE.

UNITS: mm

GSI *MicroE Systems*
Division of GSI

8 Erie Drive
Natick, MA 01760

DESCRIPTION: INTERFACE, ENCODER, 20um,
TAPE SCALE w/INDEX AND
REFERENCE MARKERS,
MERCURY II SENSOR

SIZE	DWG. NO.	REV.
B	ID-00336	5

SCALE: CAD FILE: 3RD ANGLE PROJECTION SHEET 3 OF 3

THESE DRAWINGS AND SPECIFICATIONS ARE THE PROPERTY OF MicroE Systems Corp. AND SHALL NOT BE REPRODUCED OR COPIED OR USED AS THE BASIS FOR MANUFACTURE OR SALE OF APPARATUS WITHOUT EXPRESS WRITTEN AUTHORIZATION FROM MicroE Systems Corp.

REVISIONS				
LTR	ECO	DESCRIPTION	DATE	APPROVED
S2	---	INITIAL	10/18/06	MF
3	1969	INDEX LIMIT MARKER LENGTH WAS 20mm. SEE ECO	2/11/08	MF
4	1985	SENSOR HEIGHT 6.6 WAS 6.63, CABLE LENGTH 37.1 WAS 26.0	3/14/08	VB

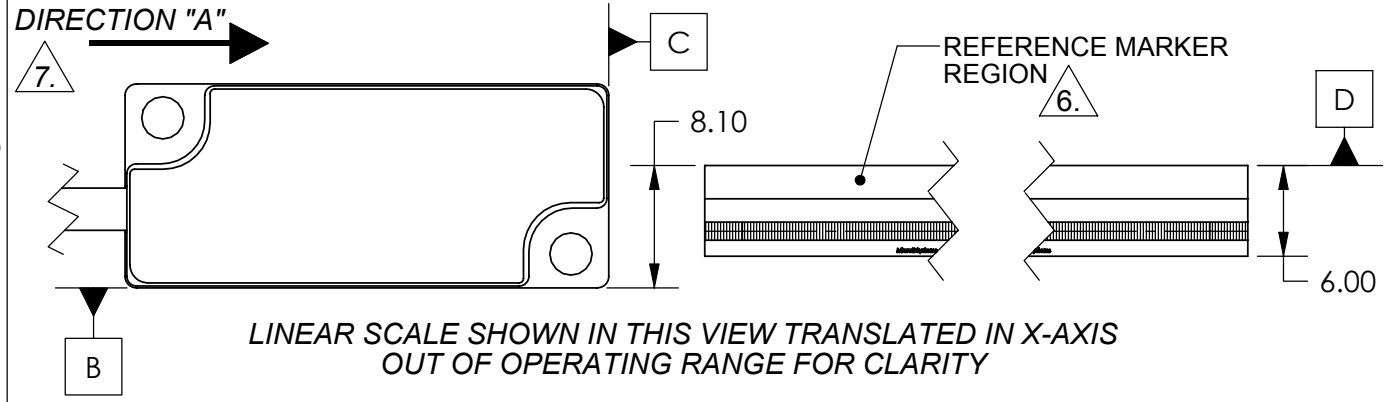

LINEAR SCALE SHOWN IN THIS VIEW TRANSLATED IN X-AXIS OUT OF OPERATING RANGE FOR CLARITY

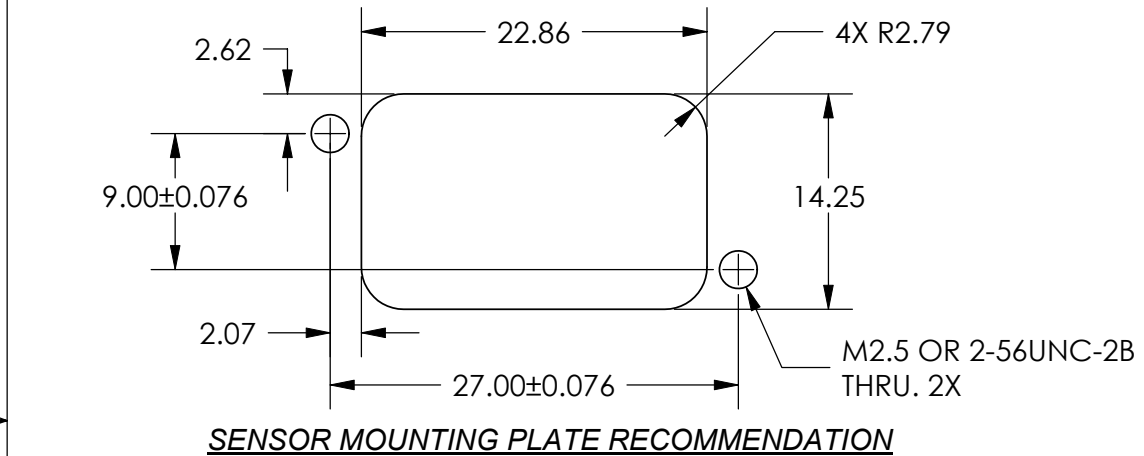

SENSOR MOUNTING PLATE RECOMMENDATION

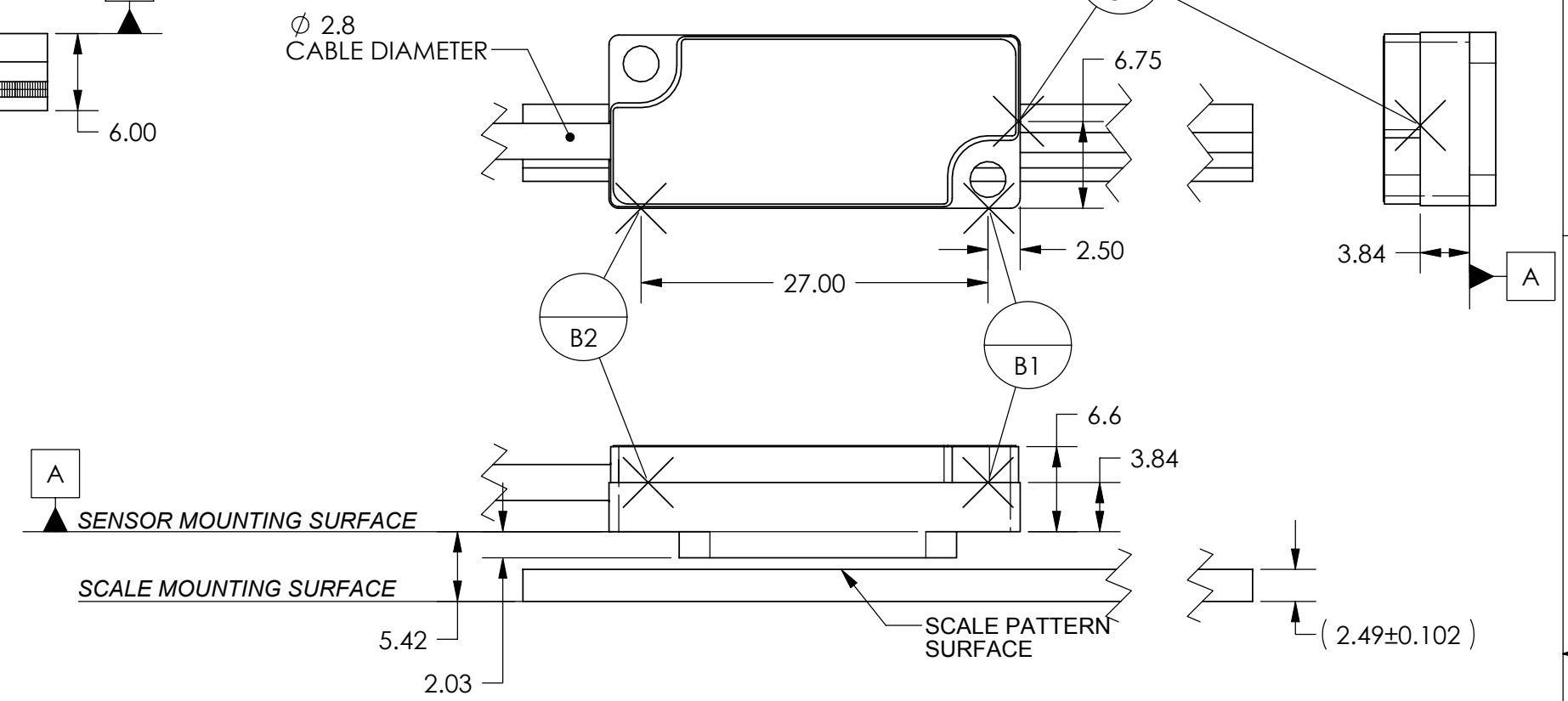

- NOTES:
- RECOMMENDED MOUNTING HARDWARE:
2-56 or M2.5 SCREWS
 - IF BENCHING PINS ARE TO BE USED, PINS MUST BE PLACED ALONG DATUM EDGES OF BOTH THE SENSOR AND THE SCALE FOR PROPER ALIGNMENT. (REFERENCE DATUMS B1, B2, AND C1 FOR SENSOR BENCHING PINS).
 - HEIGHT OF SENSOR BENCHING PINS MUST BE A MINIMUM OF 4.06mm IN HEIGHT FROM DATUM A.
 - HEIGHT OF SCALE BENCHING PINS NOT TO EXCEED THE THICKNESS OF THE SCALE.
 - RECOMMENDED SENSOR MOUNTING PLATE THICKNESS:
MINIMUM: 4 SCREW THREADS
MAXIMUM: ALLOW CLEARANCE TO SCALE AND SCALE MOUNTING HARDWARE (BENCHING SURFACES, TRENCHES, ETC.)
 - SEE PAGE 2 FOR DIMENSIONS FOR LOCATIONS OF REFERENCE MARKERS.
 - SEE INTERFACE DRAWING ID-00340 (INTERPOLATOR ELECTRONICS) FOR DIRECTIONALITY.

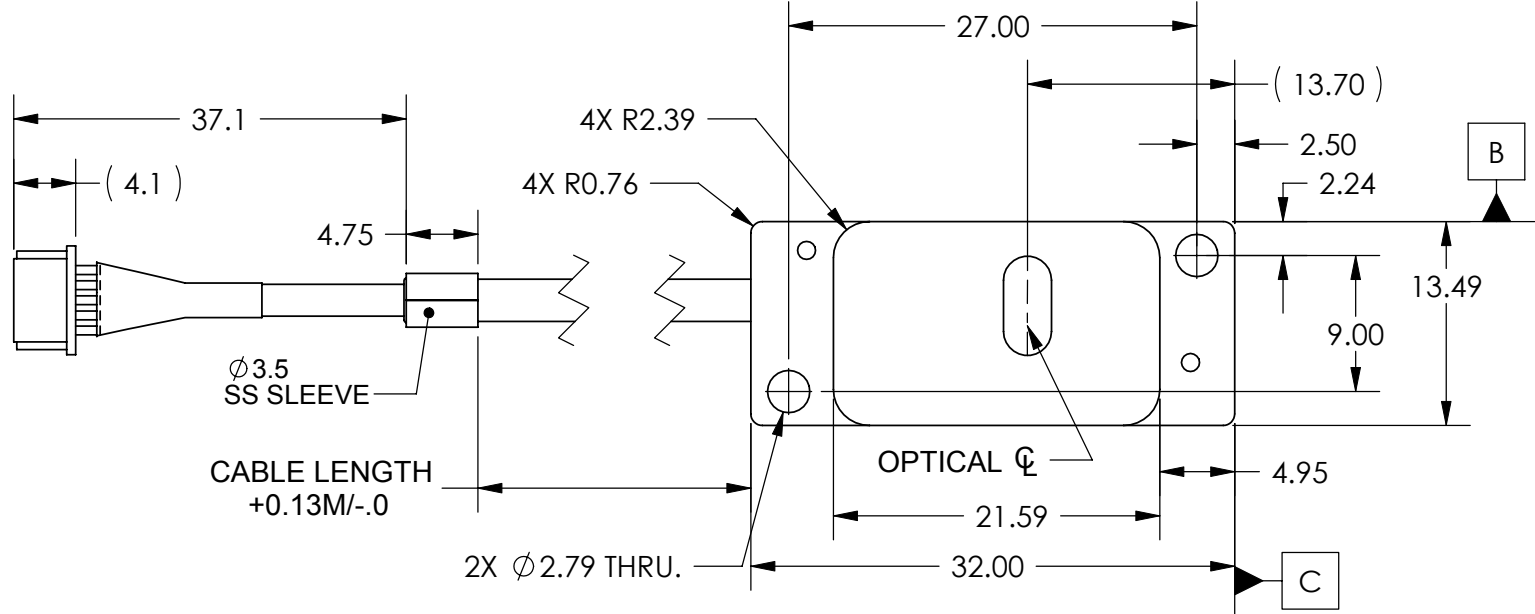
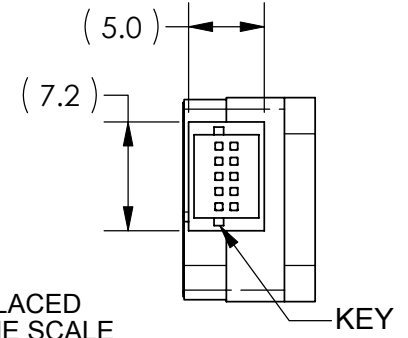

Cable Lengths	
.5M	
1M	
3M	
5M	

UNLESS OTHERWISE SPECIFIED ALL DIMENSIONS ARE IN MILLIMETERS DIM. APPLY AFTER PROCESSING INTERPRET ALL GEOMETRIC TOLS. PER ANSI Y14.5M-1994

TOLERANCES ARE:
DECIMALS: .X ± .25
.XX ± .13
ANGULAR: ±30 MIN.

APPROVALS	DATE
DRAWN S.BUTURLIA	9/25/06
CHECKED	
ENGRG. A.GOLDMAN	10/18/06
MFG ENG T.GARCIA	10/18/06
QA A.VILLARROEL	10/18/06

UNITS: mm

GSI MicroE Systems
Division of GSI

8 Erie Drive
Natick, MA 01760

DESCRIPTION: INTERFACE, ENCODER, 20um, SHORT LINEAR SCALE w/INDEX and REFERENCE MARKERS, MERCURY II SENSOR

SIZE	DWG. NO.	REV.
B	ID-00337	4

SCALE: CAD FILE: 3RD ANGLE PROJECTION SHEET 1 OF 2

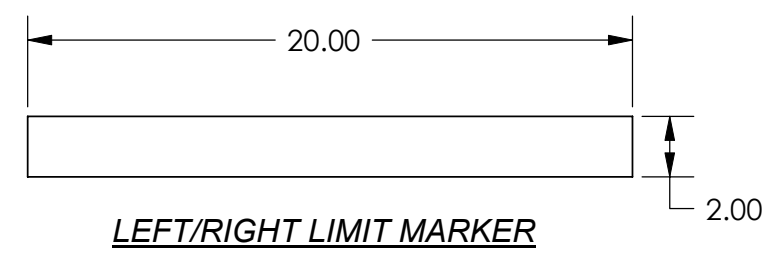
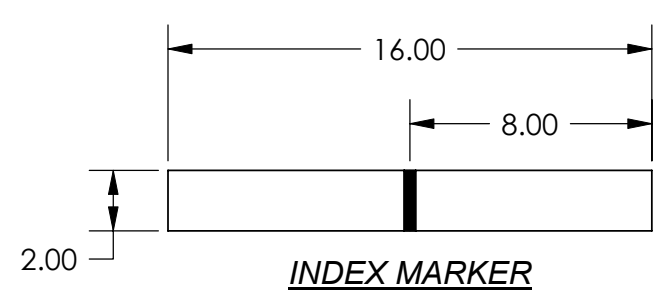
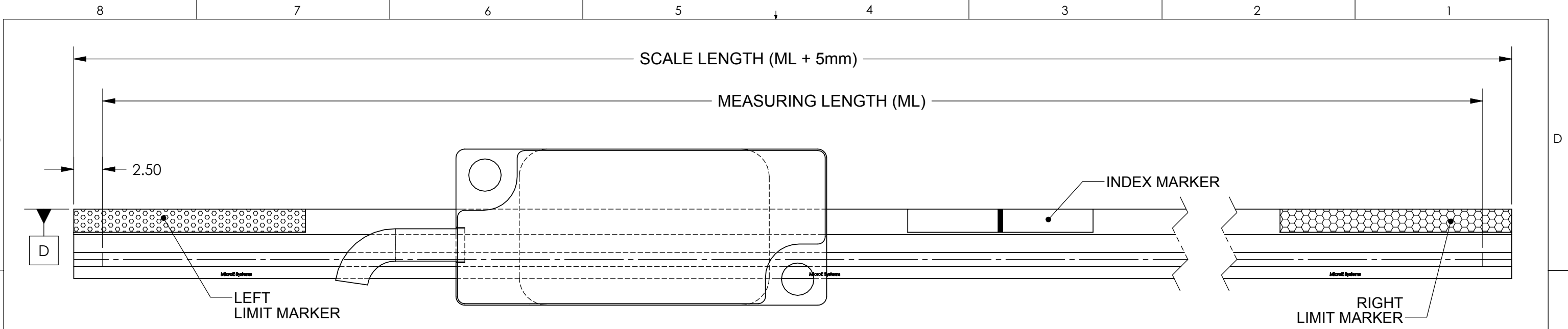

- NOTES:
- NOTE DATUM EDGE OF GLASS SCALE AND REFERENCE MARKER REGION BEFORE APPLYING MARKERS.
 - LIMITS AND INDEX MARKERS ARE OPTIONAL (SEE INSTALLATION MANUAL).
 - LIMITS AND INDEX MARKERS SHALL NOT OVERLAP (MAY CAUSE INTERFERENCE WITH SENSOR).
 - FOR LONGER OR SHORTER LENGTHS OF MARKERS CONTACT MICROE SYSTEMS FOR DETAILS.
 - FOR SHORTER LENGTHS OF LINEAR GLASS THAN 70mm CONTACT MICROE SYSTEMS FOR REQUIREMENTS.
 - LINEAR GLASS SCALES CAN HAVE INDEX AND LIMIT MARKERS PRINTED ON THEM IN LOCATION DESIRED BY CUSTOMER, CONTACT MICROE SYSTEMS FOR FURTHER DETAILS.

SCALE IDENTIFICATION AND SIZE.

Scale Identification	Measuring Length (ML)	Scale Length
MILXXX	XXXmm - 5mm	XXXmm
(Min.) MIL70	70mm - 5mm = 65mm	70mm
(Max.) MIL130	130mm - 5mm = 125mm	130mm

UNITS: mm

GSI *MicroE Systems*
 Division of GSI

8 Erie Drive
 Natick, MA 01760

DESCRIPTION: INTERFACE, ENCODER, 20um,
 SHORT LINEAR SCALE w/INDEX
 and REFERENCE MARKERS,
 MERCURY II SENSOR

SIZE B	DWG. NO. ID-00337	REV. 4
--------	-------------------	--------

SCALE: CAD FILE: 3RD ANGLE PROJECTION SHEET 2 OF 2

THESE DRAWINGS AND SPECIFICATIONS ARE THE PROPERTY OF MicroE Systems Corp. AND SHALL NOT BE REPRODUCED OR COPIED OR USED AS THE BASIS FOR MANUFACTURE OR SALE OF APPARATUS WITHOUT EXPRESS WRITTEN AUTHORIZATION FROM MicroE Systems Corp.

REVISIONS				
LTR	ECO	DESCRIPTION	DATE	APPROVED
S2	---	INITIAL	10/18/06	MF
3	1969	INDEX LIMIT MARKER LENGTH WAS 20mm. SEE ECO	2/11/08	MF
4	1985	SENSOR HEIGHT 6.6 WAS 6.63, CABLE LENGTH 37.1 WAS 26.0	3/14/08	VB

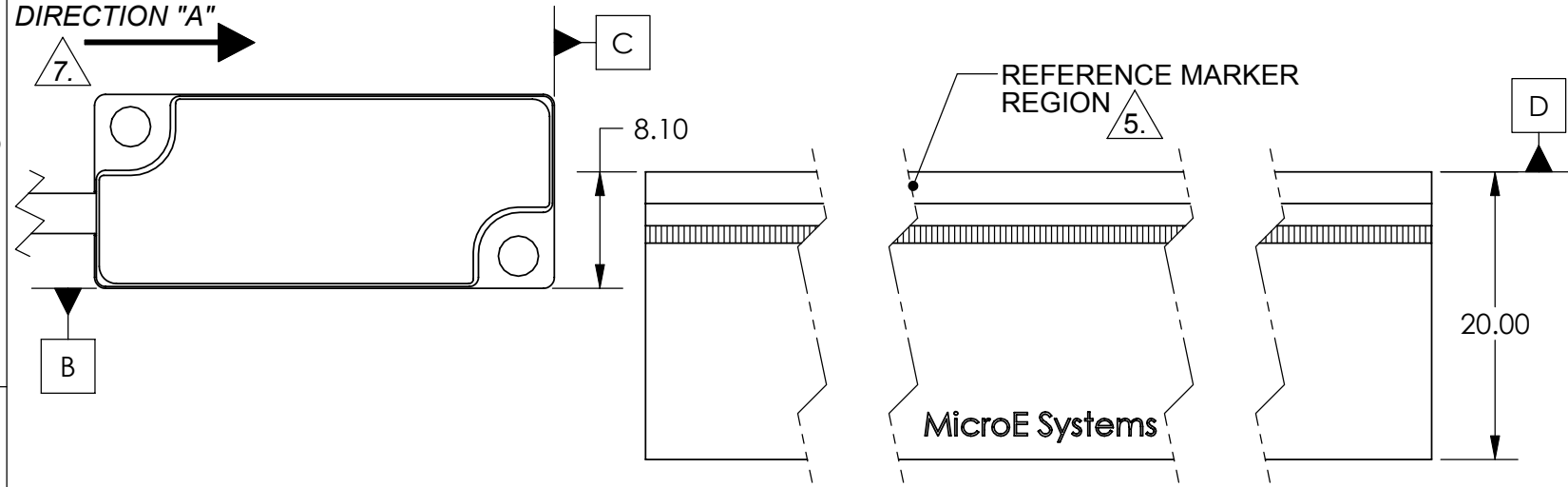

LINEAR SCALE SHOWN IN THIS VIEW TRANSLATED IN X-AXIS OUT OF OPERATING RANGE FOR CLARITY

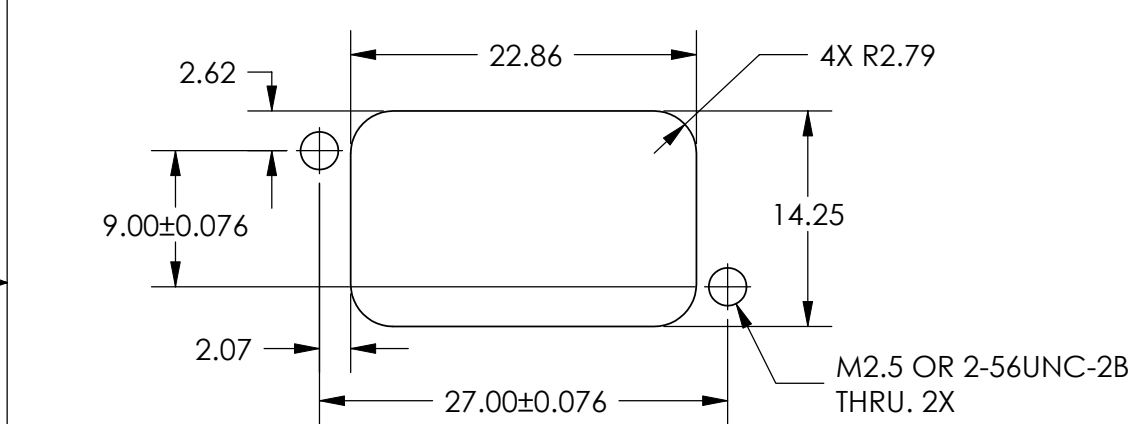
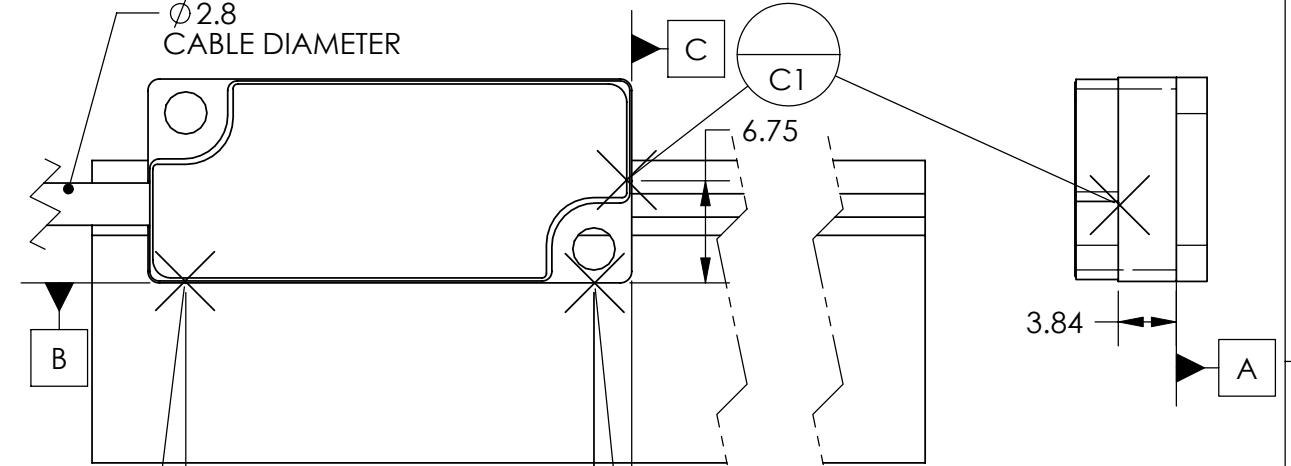

SENSOR MOUNTING PLATE RECOMMENDATION

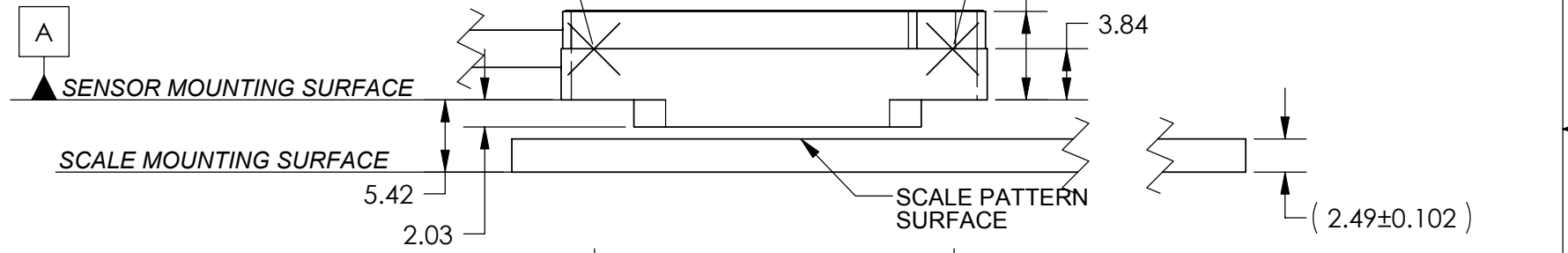

- NOTES:
1. RECOMMENDED MOUNTING HARDWARE:
2-56 or M2.5 SCREWS
 2. IF BENCHING PINS ARE TO BE USED, PINS MUST BE PLACED ALONG DATUM EDGES OF BOTH THE SENSOR AND THE SCALE FOR PROPER ALIGNMENT. (REFERENCE DATUMS B1, B2, AND C1 FOR SENSOR BENCHING PINS).
 3. HEIGHT OF SENSOR BENCHING PINS MUST BE A MINIMUM OF 4.06mm IN HEIGHT FROM DATUM A.
 4. HEIGHT OF SCALE BENCHING PINS NOT TO EXCEED THE THICKNESS OF THE SCALE.
 5. RECOMMENDED SENSOR MOUNTING PLATE THICKNESS:
MINIMUM: 4 SCREW THREADS
MAXIMUM: ALLOW CLEARANCE TO SCALE AND SCALE MOUNTING HARDWARE (BENCHING SURFACES, TRENCHES, ETC.)

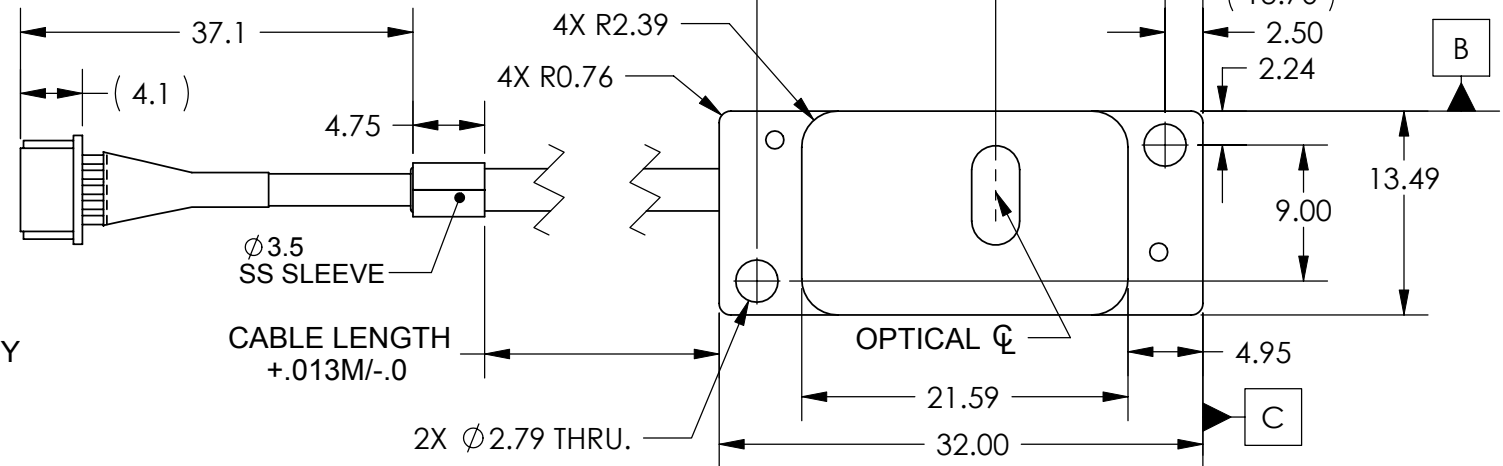

6. SEE PAGE 2 FOR DIMENSIONS FOR LOCATIONS OF REFERENCE MARKERS.
7. SEE INTERFACE DRAWING ID-00340 (INTERPOLATOR ELECTRONICS) FOR DIRECTIONALITY.

Cable Lengths	
.5M	
1M	
3M	
5M	

UNLESS OTHERWISE SPECIFIED ALL DIMENSIONS ARE IN MILLIMETERS DIM. APPLY AFTER PROCESSING INTERPRET ALL GEOMETRIC TOLS. PER ANSI Y14.5M-1994		APPROVALS		DATE
TOLERANCES ARE: DECIMALS: .X ± .25 .XX ± .13		DRAWN S.BUTURLIA		9/25/06
		CHECKED		
		ENGRG. A.GOLDMAN		10/18/06
		MFG ENG T.GARCIA		10/18/06
		QA A.VILLARROEL		10/18/06

UNITS: mm

GSI MicroE Systems Division of GSI

8 Erie Drive
Natick, MA 01760

DESCRIPTION: INTERFACE, ENCODER, 20um, LONG LINEAR SCALE w/INDEX and REFERENCE MARKERS, MERCURY II SENSOR

SIZE	DWG. NO.	REV.
B	ID-00338	4

SCALE: CAD FILE: 3RD ANGLE PROJECTION SHEET 1 OF 2

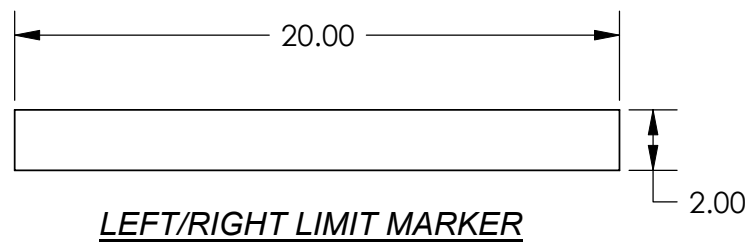
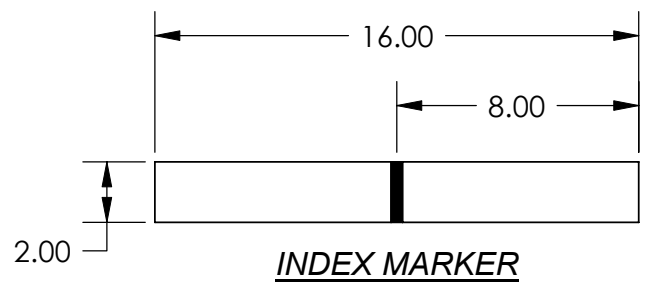
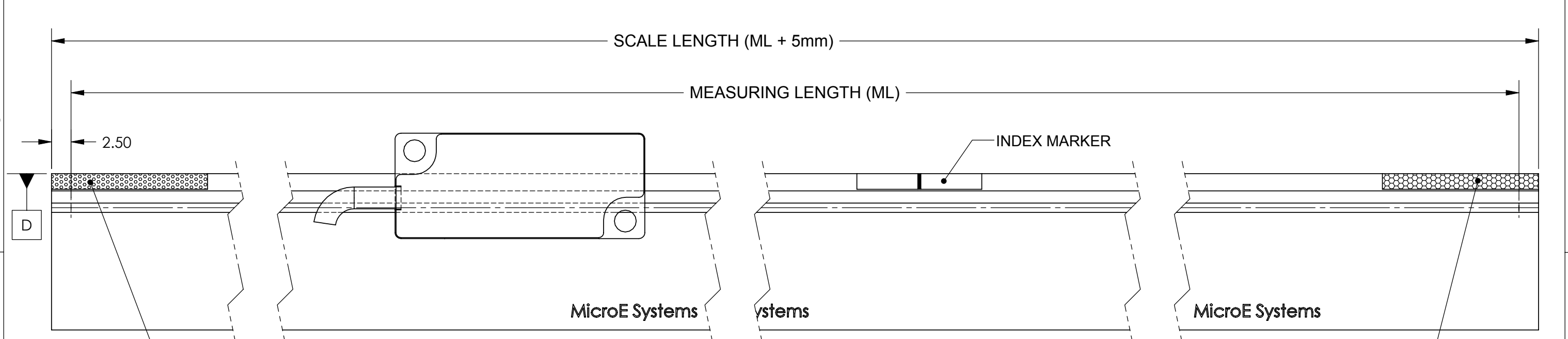

- NOTES:**
1. NOTE DATUM EDGE OF GLASS SCALE AND REFERENCE MARKER REGION BEFORE APPLYING MARKERS.
 2. LIMITS AND INDEX MARKERS ARE OPTIONAL (SEE INSTALLATION MANUAL).
 3. LIMITS AND INDEX MARKERS SHALL NOT OVERLAP (MAY CAUSE INTERFERENCE WITH SENSOR).
 4. FOR LONGER OR SHORTER LENGTHS OF MARKERS CONTACT MICROE SYSTEMS FOR DETAILS.
 5. LINEAR GLASS SCALES CAN HAVE INDEX AND LIMIT MARKERS PRINTED ON THEM IN LOCATION DESIRED BY CUSTOMER, CONTACT MICROE SYSTEMS FOR FURTHER DETAILS.

SCALE IDENTIFICATION AND SIZES:

Scale Identification	Measuring Length (ML)	Scale Length
MIILXXXX	XXXXmm - 5mm	XXXXmm
(Min.) MIIL135	135mm - 5mm = 130mm	135mm
(Max.) MIIL1000	1000mm - 5mm = 995mm	1000mm

UNITS: mm

GSI
MicroE Systems
Division of GSI

8 Erie Drive
Natick, MA 01760

DESCRIPTION: INTERFACE, ENCODER, 20um, LONG LINEAR SCALE w/INDEX and REFERENCE MARKERS, MERCURY II SENSOR

SIZE B	DWG. NO. ID-00338	REV. 4
--------	-------------------	--------

SCALE: CAD FILE: 3RD ANGLE PROJECTION SHEET 2 OF 2

THESE DRAWINGS AND SPECIFICATIONS ARE THE PROPERTY OF MicroE Systems Corp. AND SHALL NOT BE REPRODUCED OR COPIED OR USED AS THE BASIS FOR MANUFACTURE OR SALE OF APPARATUS WITHOUT EXPRESS WRITTEN AUTHORIZATION FROM MicroE Systems Corp.

- NOTES:**
1. RECOMMENDED MOUNTING HARDWARE:
2-56 or M2.5 SCREWS
 2. IF BENCHING PINS ARE TO BE USED, PINS MUST BE PLACED ALONG DATUM EDGES OF SENSOR FOR PROPER ALIGNMENT.
(REFERENCE DATUMS B1, B2, AND C1).
 3. HEIGHT OF SENSOR BENCHING PINS MUST BE A MINIMUM OF 4.06mm IN HEIGHT FROM DATUM A.
 4. RECOMMENDED SENSOR MOUNTING PLATE THICKNESS:
MINIMUM: 4 SCREW THREADS
MAXIMUM: ALLOW CLEARANCE TO SCALE AND SCALE MOUNTING HARDWARE (BENCHING SURFACES, TRENCHES, ETC.)
5. SEE INTERFACE DRAWING ID-00340 (INTERPOLATOR ELECTRONICS) FOR DIRECTIONALITY.

REVISIONS				
LTR	ECO	DESCRIPTION	DATE	APPROVED
S2	---	INITIAL	10/18/06	MF
3	1834	CORRECTED DIMS IN SCALE ID SECTION OF TABLE.	5/14/07	SB
4	1985	SENSOR HEIGHT 6.6 WAS 6.63, CABLE LENGTH 37.1 WAS 26.0	3/14/08	VB

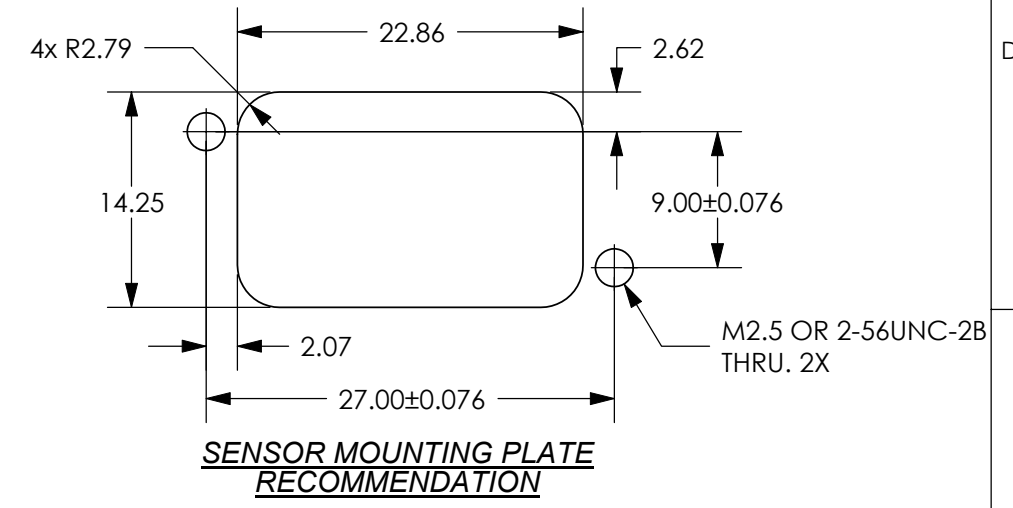
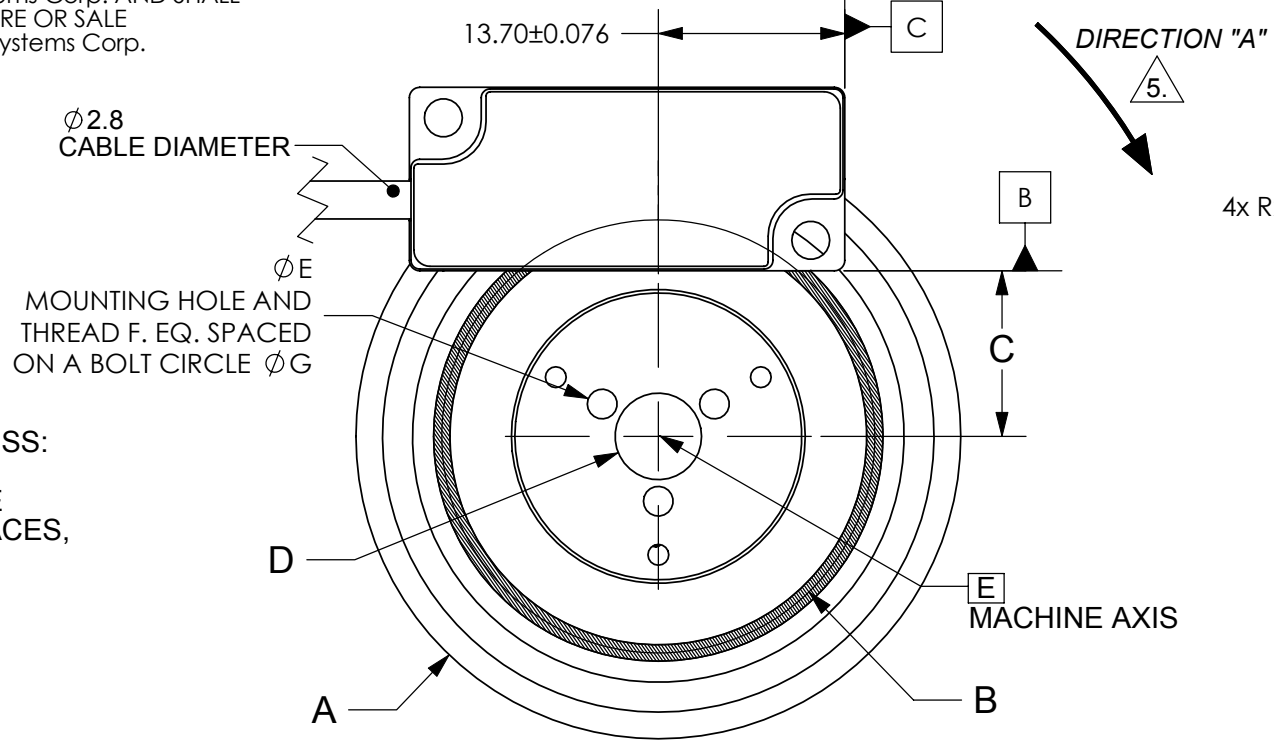

Cable Lengths	
.5M	
1M	
3M	
5M	

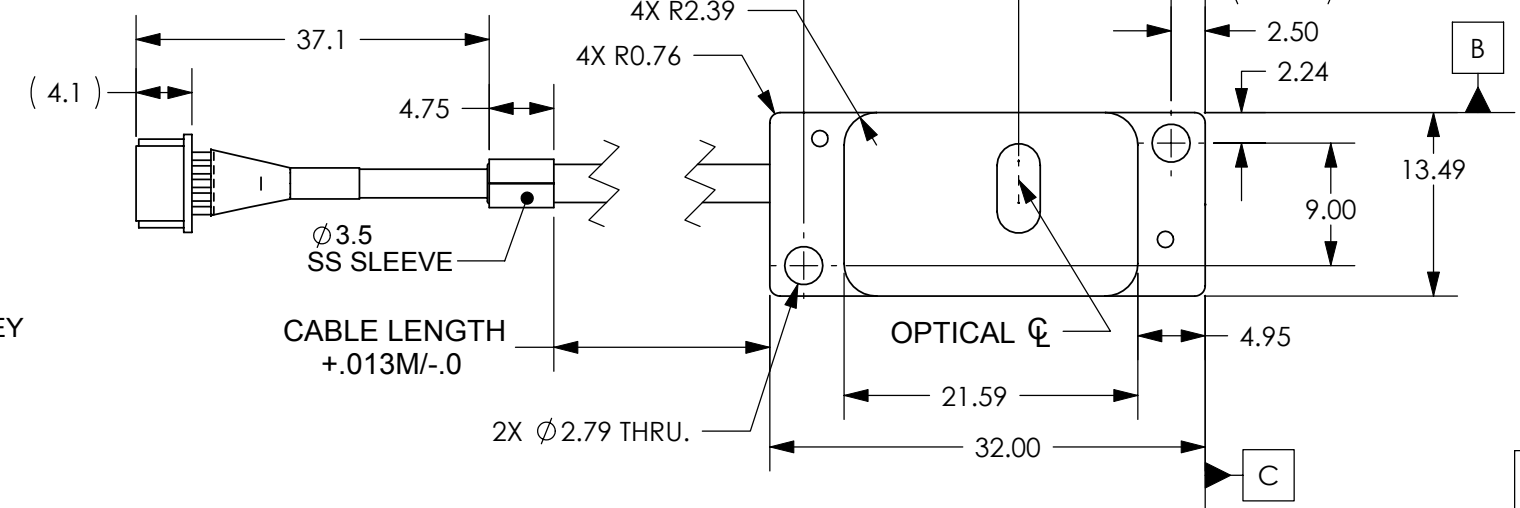
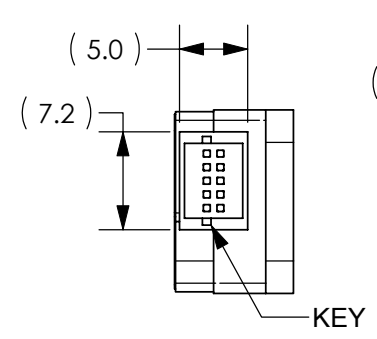
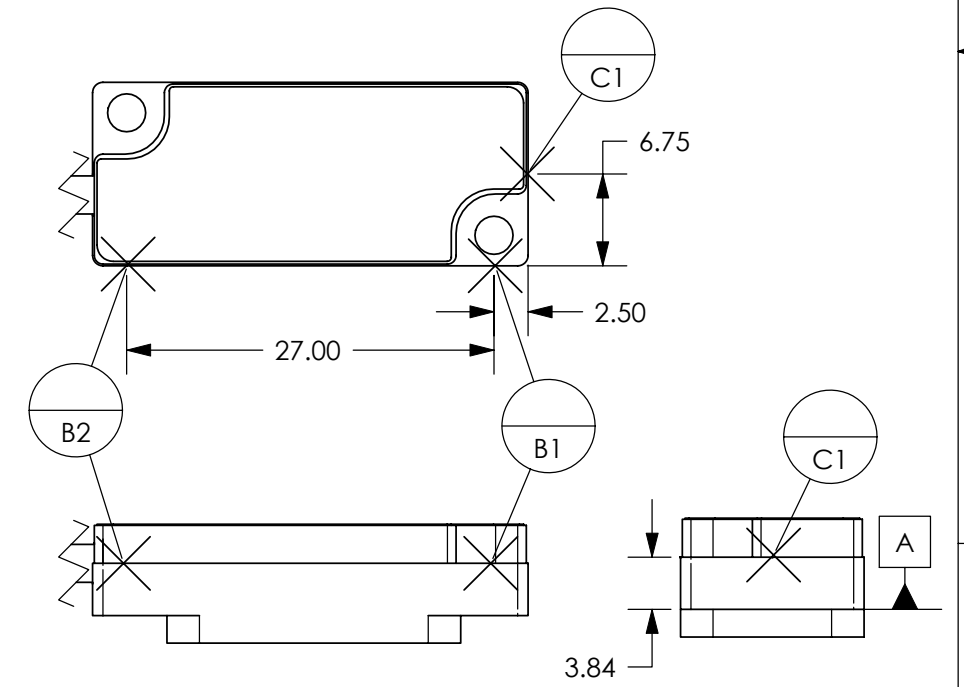
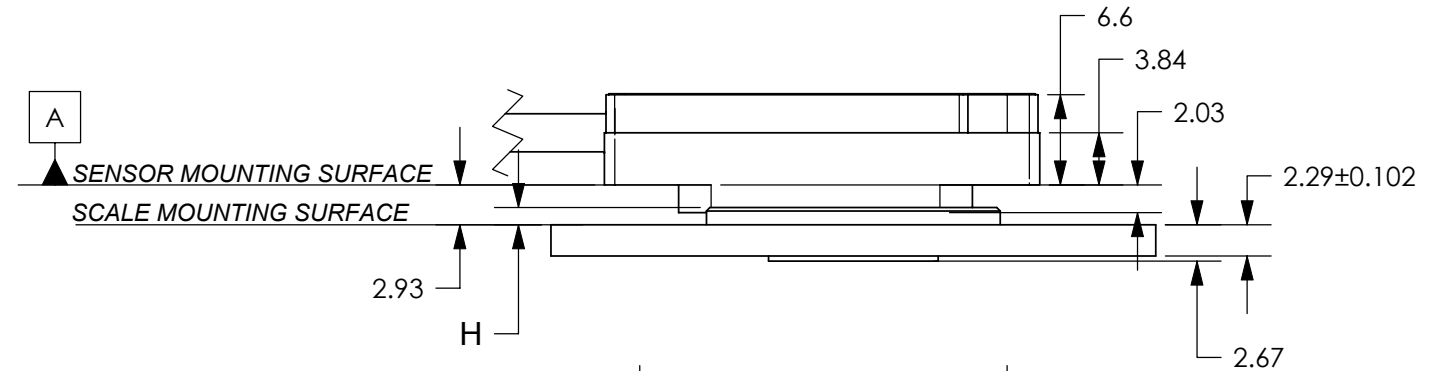

SCALE/HUB IDENTIFICATION AND SIZE.

Scale/Hub Identification	Counts/Rev	Dim. A Scale O.D.	Scale I.D.	Dim. B Optical Dia.	Dim. C Mounting Dim.	Dim D. Hub I.D.	Dim E. Mounting Hole Dia.	Thread F	Dim G. Bolt Circle	Dim. H Hub Height
R4513 / HI	5,000	44.45	12.70+/-0.13	31.83	11.96+/-0.05	6.358+.013/-0.000	1.78	2-56	9.53	1.27
R6425 / HJ	8,192	63.50	25.40+/-0.13	52.15	22.12+/-0.05	12.708+.013/-0.000	3.45	8-32	19.05	1.52
R12151 / HK	16,384	120.65	50.80+/-0.13	104.30	48.20+/-0.05	25.408+.013/-0.000	3.45	8-32	38.10	2.03

UNLESS OTHERWISE SPECIFIED ALL DIMENSIONS ARE IN MILLIMETERS DIM. APPLY AFTER PROCESSING INTERPRET ALL GEOMETRIC TOLS. PER ANSI Y14.5M-1994

TOLERANCES ARE:
DECIMALS: .X ± .25
.XX ± .13

ANGULAR: ±30 MIN.

APPROVALS		DATE
DRAWN	S.BUTURLIA	9/25/06
CHECKED		
ENGRG.	A.GOLDMAN	10/18/06
MFG ENG	T.GARCIA	10/18/06
QA	A.VILLARROEL	10/18/06

MicroE Systems
Division of GSI

8 Erie Drive
Natick, MA 01760

DESCRIPTION:
INTERFACE, ENCODER, 20um, ROTARY SCALE w/INDEX and HUB, MERCURY II SENSOR

SIZE: B DWG. NO. **ID-00339** REV. **4**

SCALE: CAD FILE: 3rd ANGLE PROJECTION SHEET 1 OF 1

THESE DRAWINGS AND SPECIFICATIONS ARE THE PROPERTY OF MicroE Systems Corp. AND SHALL NOT BE REPRODUCED OR COPIED OR USED AS THE BASIS FOR MANUFACTURE OR SALE OF APPARATUS WITHOUT EXPRESS WRITTEN AUTHORIZATION FROM MicroE Systems Corp.

REVISIONS				
LTR	ECO	DESCRIPTION	DATE	APPROVED
S1	----	INITIAL	10/18/06	MF

TABLE 1.

DB15, HD Plug Connector	
Pin	Function
1	A+
2	B+
3	Left Limit Out-
4	Alarm
5	Left Limit Out+
6	Right Limit Out-
7	Index+
8	Index-
9	A-
10	B-
11	GND
12	+5V Power In
13	Right Limit Out+
14	N/C
15	N/C

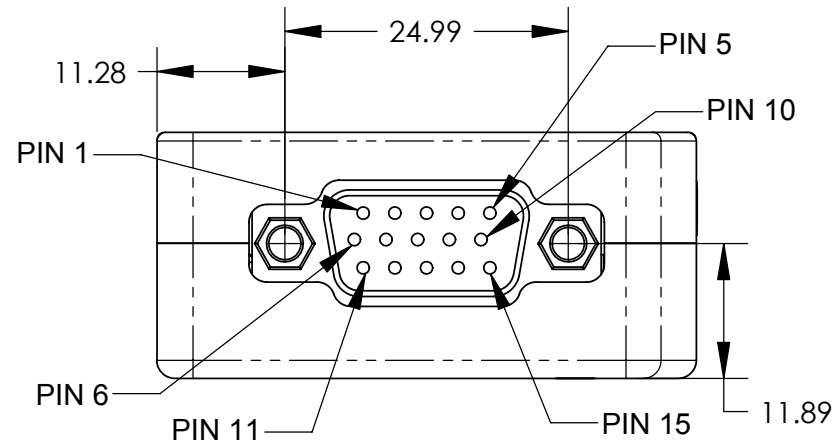
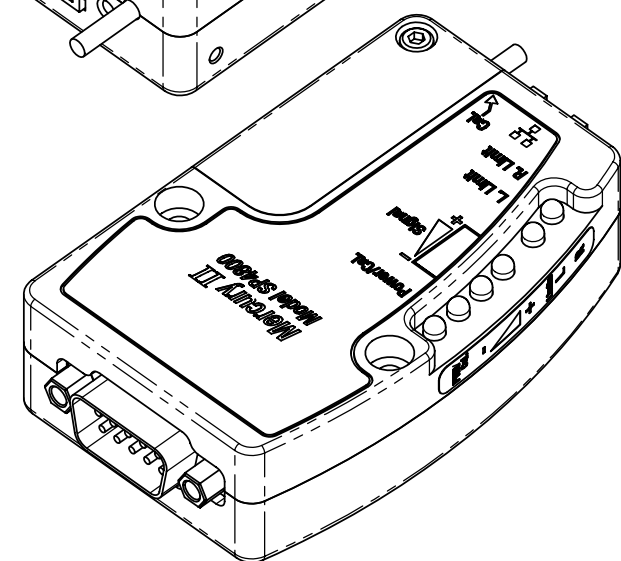
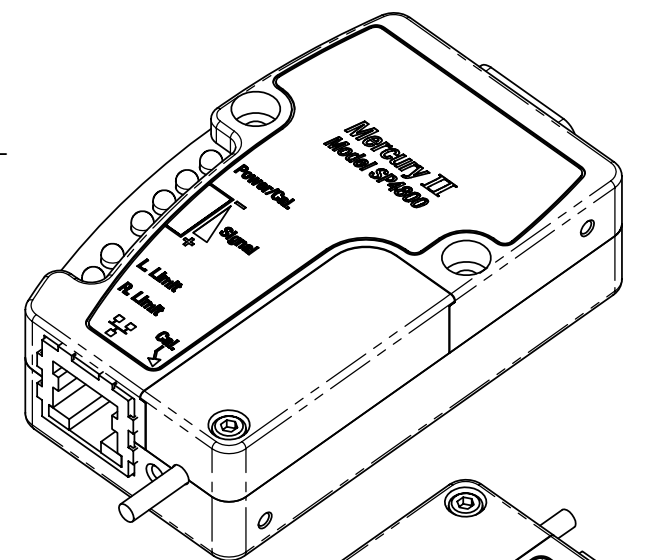
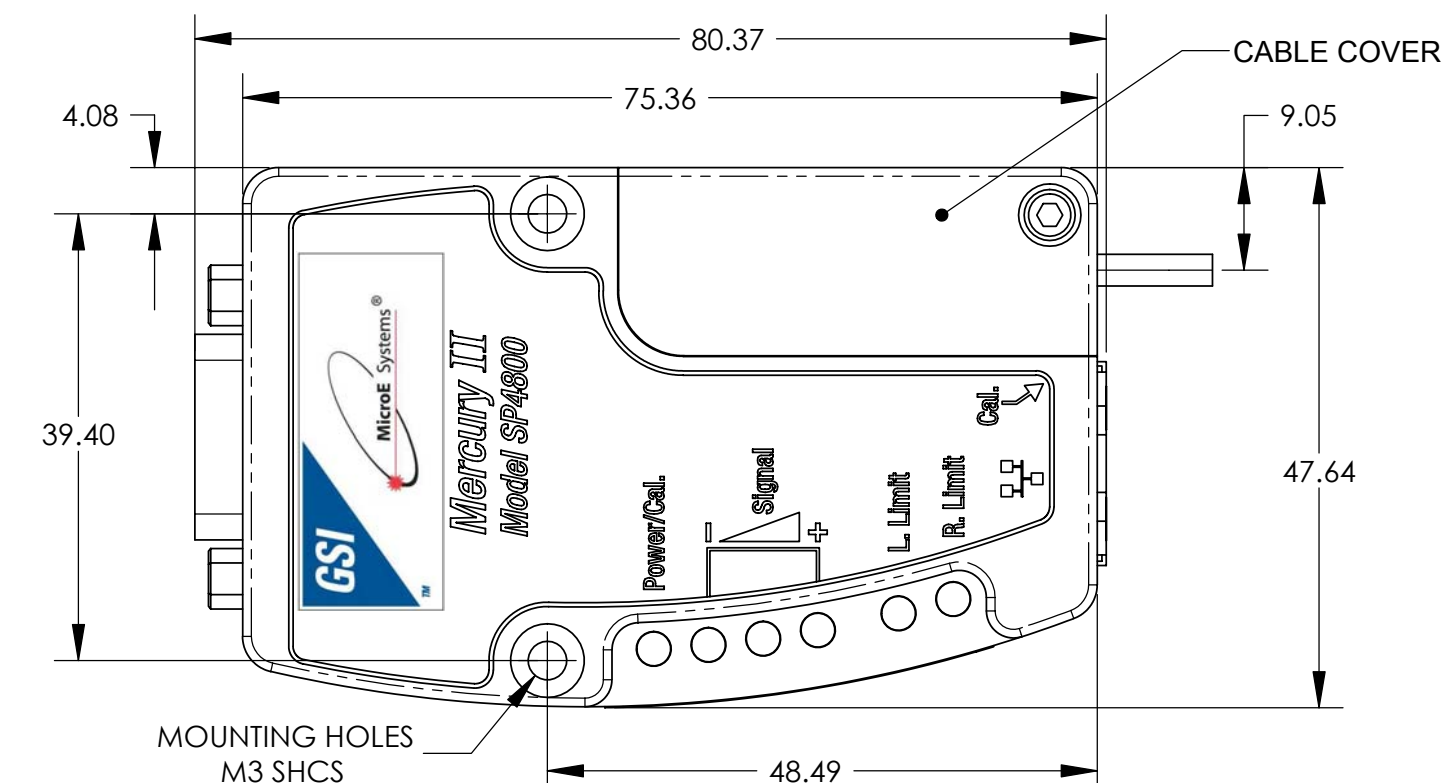
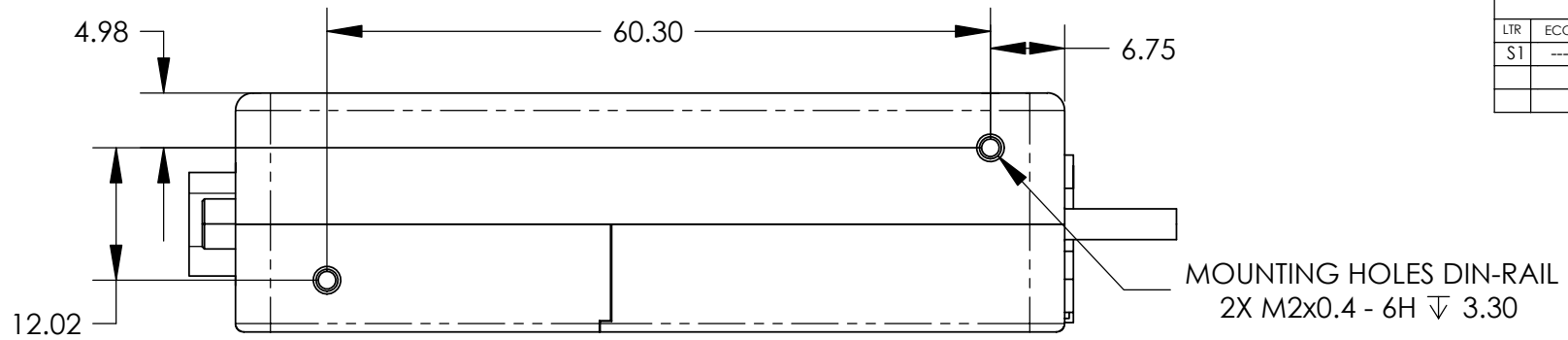

SEE TABLE 1. FOR PIN FUNCTIONS

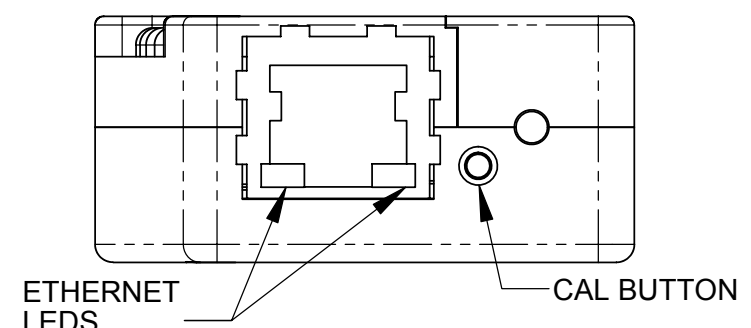
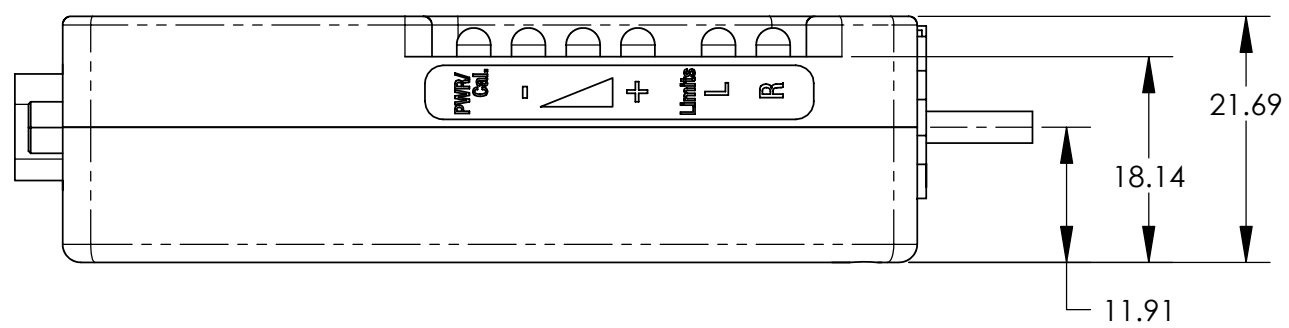

NOTES:
 1. WHEN SCALE MOVES IN DIRECTION "A" WITH RESPECT TO A STATIONARY SENSOR, OUTPUT SIGNAL A+ (PIN 1) LEADS OUTPUT SIGNAL B+ (PIN 2).
 SEE SENSOR INTERFACE DRAWINGS FOR DIRECTIONALITY (NOTE CABLE ORIENTATION).

UNLESS OTHERWISE SPECIFIED ALL DIMENSIONS ARE IN MILLIMETERS DIM. APPLY AFTER PROCESSING INTERPRET ALL GEOMETRIC TOLS. PER ANSI Y14.5M-1994

TOLERANCES ARE:
 DECIMALS: .X ± .25
 .XX ± .13

ANGULAR: ±30 MIN.

APPROVALS	DATE
DRAWN: S.BUTURLIA	9/25/06
CHECKED:	
ENGRG: A.GOLDMAN	10/18/06
MFG ENG: T.GARCIA	10/18/06
QA: A.VILLARROEL	10/18/06

UNITS: mm

MicroE Systems
 Division of GSI

8 Erie Drive
 Natick, MA 01760

DESCRIPTION:
INTERFACE, MERCURY II INTERPOLATOR ELECTRONICS

SIZE: B DWG. NO. ID-00340 REV. S1

SCALE: CAD FILE: 3RD ANGLE PROJECTION SHEET 1 OF 1